



Haldimand
County

Accessible Design Standards

ADS 2023



Table of Contents

INTRODUCTION.....	10
Mandate.....	11
Scope and Application	12
Existing Barriers and Conditions	13
EXTERIOR STANDARDS.....	14
Parking.....	15
How the Standard applies	15
Parking Spaces.....	15
Parking Design and Layout	17
Signage and Pavement Markings.....	18
On-Street Parking	19
Exterior Paths of Travel.....	19
How the standard applies.....	19
General standards for Exterior Paths of Travel	19
Sidewalks.....	19
Trails.....	20
Walkways.....	20
Curb Ramps and Depressed Curbs	20
INTERIOR.....	25
Entrances	26
How the standard applies.....	26
General standards for Entrances	26
Main or Primary Entrance Features.....	26
Doors and Doorways.....	27
How the standard applies.....	27
Clear Width.....	27
Thresholds	28
Door Hardware	28

Automatic Doors	28
Power-assisted Doors.....	29
Doors Swinging into Accessible Routes	31
Approach Clearances at Doors	33
Doors in Series	35
Interior Accessible Routes.....	35
How the standard applies.....	35
General Standards for Accessible Routes	36
Clear Width.....	36
Washrooms.....	37
How the standard applies.....	37
Provision and Locations.....	38
Multiple Occupancy Washrooms.....	39
Universal Washrooms.....	41
Accessible Water Closet Stalls.....	43
Stall Doors	43
Water Closets	44
Lavatories.....	47
Washroom Amenities	48
Urinals.....	52
Showers	53
COMMON ELEMENTS: INTERIOR AND EXTERIOR.....	58
Ground and Floor Surfaces	59
How the standard applies.....	59
Surfaces.....	59
Gratings and Surfaces	60
Ramps	61
How the standard applies.....	61
Design Features	61
Running Slope/Cross Slope	62

Edge Protection	62
Colour Contrasting Strips.....	62
Landings	62
Ramp Handrails and Guards.....	62
Stairs.....	63
How the standard applies.....	63
Design Features	64
Treads and Risers	64
Nosings.....	64
Tactile Walking Surface Indicators (TWSIs) at Stairs.....	66
Stair Handrails and Guards.....	66
Handrails and Guards - General.....	68
How the standard applies.....	68
Guards.....	68
Handrails	68
Rest Areas.....	69
How the standard applies.....	69
Consultation Requirements.....	69
Design and Placement	69
Tactile Walking Surface Indicators (TWSIs).....	71
How the standard applies.....	71
Design Features	71
Seating, Tables, and Work Surfaces.....	72
How the standard applies.....	72
Benches and Seats.....	72
Tables and Work Surfaces	73
CONTROLS AND OPERATIONG MECHANISMS	75
General Controls and Operations.....	76
How the standard applies.....	76
Design Features	76

Floor Space.....	77
Assistive Listening Devices.....	78
How the standard applies.....	78
Assistive Listening Design Features	79
Assistive Listening Systems.....	79
Acoustics.....	80
How the standard applies.....	80
Design Features.....	80
Security Systems.....	80
How the standard applies.....	80
Design Features.....	81
Fire and Life Safety Systems.....	81
How the standard applies.....	81
Fire Safety and Evacuation Plans.....	82
Visual Alarm Systems.....	83
Areas of Refuge	84
Lighting	85
How the standard applies.....	85
Lighting Level Requirements	85
Lighting Design Best Practices.....	85
Signage and Wayfinding	86
How the standard applies.....	86
Signage.....	86
FACILITIES.....	90
Assembly Areas	91
How the standard applies.....	91
Design and Layout.....	91
Accessible and Adaptable Seating	91
Accessible Seating Spaces	92
Adaptable Seating	93

Storage for Mobility Aids.....	93
Meeting and Multi-Purpose Rooms.....	94
How the standard applies.....	94
Design and Layout.....	94
Cultural and Art Facilities.....	95
How the standard applies.....	95
Design and Layout.....	95
Kitchen and Kitchenettes.....	96
How the standard applies.....	96
Design and Layout.....	96
Libraries.....	97
How the standard applies.....	97
Design and Layout.....	97
Book Drop Slots.....	97
Book Stacks or Carousels.....	98
Reading Lounges and Study Areas.....	98
Recreational and Community Facilities.....	99
How the standard applies.....	99
Design and Layout.....	99
Arenas.....	99
Exercise and Fitness Facilities.....	100
Aquatics Facilities.....	100
Change Rooms.....	101
How the standard applies.....	101
Provision and Location.....	101
Design and Layout.....	101
Change Room Amenities.....	102
Universal Change Rooms or Stalls.....	103
Service Counters.....	105
How the standard applies.....	105

Provision.....	105
Design and Layout.....	106
Outdoor Public Use Eating Areas.....	107
How the standard applies.....	107
Design and Layout.....	108
Recreational Trails, Beach Access Routes and Boardwalks.....	108
How the standard applies.....	108
Recreational Trails.....	109
Beach Access Routes.....	112
Inclusive Play Spaces.....	113
How the standard applies.....	113
Consultation Requirements.....	113
Design Requirements.....	113
Summary of Key Design Considerations.....	114
Designing an Inclusive Play Space.....	116
Summary of 5 Key Features.....	117
Appendices.....	121
Definitions.....	121
Regulatory Framework.....	132
The Ontarians with Disabilities Act, 2001.....	132
The Accessibility for Ontarians with Disabilities Act (AODA, 2005).....	133
AODA Accessibility Standards.....	134
The Ontario Human Rights Code (OHRC).....	134
The Ontario Building Code (OBC, 2012).....	135
Canadian Standards Association “Accessible Design for the Built Environment” (CSA B651-12).....	135
The Ontario Planning Act.....	136
Exceptions.....	138
Principles Of Universal Design.....	138
Understanding Disability.....	139

Using a Cross-Disability Perspective.....	139
Implementation Alternatives.....	140
Feedback.....	140
Feedback Form.....	141

Table of Figures

Tables

Table 1: Total Number of Required Accessible Parking Spaces.....	16
Table 2: Approach Clearances at Doors.....	33
Table 3: Minimum Number of Required Universal Washrooms	38
Table 4: Minimum Number of Accessible Water Closet Stalls.....	38
Table 5: Accessible shower requirements.....	54
Table 6: Character requirements for signs.....	88
Table 7: Accessible seating requirements.....	91
Table 8: Ground-level component requirements.....	115

Figures

Figure 1: Examples of parking signage.....	18	
Figure 2: Concrete Sidewalk Ramps at Signalized Intersections.....	22	
Figure 3: Tactile Walking Indicator Diagram.....	24	
Figure 4: Example of clear door widths	28	
Figure 5: Example of power door button mounting locations	31	
Figure 6: Example of a guard at door.....	32	
Figure 7: Example of a recessed door	32	
Figure 8: Side-Hinged Door - Front Approach	Figure 9: Sliding Door.....	34
Figure 10: Side-Hinged Door - Hinge Side	Figure 11: Side-Hinged Door - Latch Side ...	34
Figure 12: Recessed Door - Front Approach		34
Figure 13: Turning radius between doors.....		35
Figure 14: Accessible routes width requirements.....		37
Figure 15: Width requirements for turning.....		37
Figure 16: Example of a multiple occupancy washroom.....		40
Figure 17: Example of Universal Washroom Design.....		42
Figure 18: Example of water closet stall features.....		44
Figure 19: Grab bar mounting requirements.....		46
Figure 20: Examples of grab bar designs.....		47
Figure 21: Measurements at a sink.....		48

Figure 22: Example of washroom amenities 49

Figure 23: Example of baby change tables..... 50

Figure 24: Example of an adult change table 52

Figure 25: Urinal spacing requirements..... 53

Figure 26: Example of shower design outlines 55

Figure 27: Examples of Grab Bars 57

Figure 28: Example of between surfaces; a cross section view..... 60

Figure 29: OPSD Grate Diagram..... 61

Figure 30: Example of handrail and guards..... 63

Figure 31: Nosing and stair tread depth requirements 65

Figure 32: Tactile Walking Surface Indicator at top of stairs 66

Figure 33: Stair shape 68

Figure 34: Example of bench with pad for mobility aides 71

Figure 35: Chair dimension requirements..... 73

Figure 36: Table and workplace leg clearances from side..... 74

Figure 37: Table and workplace leg clearances from above..... 74

Figure 38: Examples of various control mounting heights..... 77

Figure 39: Reaching standards..... 78

Figure 40: Example of door card reader 81

Figure 41: Fire evacuation layout 83

Figure 42: Fire alarms..... 84

Figure 43: Examples of pictogram signs for disability..... 87

Figure 44: Pictogram examples..... 89

Figure 45: Examples of accessible seating plans..... 93

Figure 46: Layout of accessible meeting room..... 95

Figure 47: Accessible library returns counter 98

Figure 48: Path of travel in locker room 103

Figure 49: Example of Universal Change Room Design 105

Figure 50: Accessible counter examples..... 107

Figure 51: Accessible picnic area and bench 108

Figure 52: Trailhead design 110

Figure 53: Example of a universal trail assessment 112

Figure 54: Turning radius on playset 115

Figure 55: Example of typical play space features..... 117



Haldimand
County

INTRODUCTION

Mandate

Haldimand County (“the County”) believes in striving to develop accessible environments for all, embracing the principles of **universal design**, defined as the: “design of products and environments to be usable by all people, to the greatest extent possible, without the need for adaptation or specialized design.” (Source: North Carolina State University, Center for Universal Design, 1997.)

To facilitate meeting this goal, the County has established Accessibility Design Standards (“the Standards”) to provide practical examples of solutions that optimize accessibility for new construction or for the redevelopment of existing spaces and facilities owned, leased or operated by the County.

Through these efforts, the County intends to demonstrate leadership within the community to encourage the private sector to follow the County’s designs related to both existing and new facilities.

The design standards were established with recognition of the following:

- **Diversity:** To encourage the inclusion and integration of diverse communities, appreciating differences, while promoting a common goal to make Haldimand County a more accessible place for all;
- **Barrier Removal:** To prevent and remove obstructions that create exclusion;
- **Provincial Directions:** To integrate accessibility standards in the areas of customer service, information and communication, employment, transportation and the built environment, developed under the Accessibility for Ontarians with Disabilities Act (AODA) initiative; and
- **Changing Demographics:** To recognize that people with varying types of disabilities comprise a significant proportion of the population. The proportion of seniors within the Canadian population is also increasing rapidly and for some seniors, acquiring a disability may also increase with age. Currently, people with disabilities represent one in seven Ontarians. Due primarily to aging, one in every five Ontarians is expected to have a disability within 20 years.

With accessibility requirements and related best practices continually evolving, the development and update of the Standards will be an ongoing process, evolving over time to meet future changes that may be related to any Ontario Building Code (OBC), Canadian Standards Association (CSA) and AODA updates. As such, authority will be delegated to the County's Senior Management Team (SMT) to update as required without the express approval of Haldimand County Council.

Scope and Application

The accessible design criteria provided in these Standards aims to make all County-owned or leased spaces, buildings, infrastructure and elements accessible to Haldimand's residents, employees and visitors, as part of any new construction or redevelopment activities. The County recognizes that addressing accessibility issues as early as possible in the planning and design phases of new construction and redevelopment projects is the most practical and cost-effective way to ensure accessible and inclusive environments.

The intent is for the County to clearly identify the accessibility criteria and features included in the procurement of its facilities and to demonstrate proactive steps towards making all facilities and sites accessible.

Across the corporation, these Standards are understood to be:

- Mandatory for all new construction and redevelopment of existing spaces and facilities, owned, leased or operated by Haldimand County;
- Intended to apply to the greatest extent possible for retrofit, alterations or additions to existing spaces and facilities owned, leased or operated by Haldimand County;
- Encouraged to be implemented by other sectors and organizations within Haldimand County; and,
- Recognized as addressing the needs of diverse users, with or without disabilities, to ensure inclusive environments for all.

Although the design criteria contained in these Standards may differ from the requirements of the AODA, Ontario Building Code and the Canadian Standards Association's "Accessible Design for the Built Environment" (CSA B651-12), the intent is that AODA, OBC and CSA requirements are used as the baseline and minimum requirements that are to be applied. The Standards reflect an optimal level of accessibility for the design of the built environment, as the Standards are intended to meet or go beyond the requirements of the AODA, OBC and CSA.

Exceptions to the application of the Standards includes the following spaces and areas:

- equipment service rooms or spaces;
- elevator machine rooms;
- janitor rooms;
- crawl spaces; and
- other similar areas identified in the Ontario Building Code.

Existing Barriers and Conditions

Barrier removal for existing County spaces, infrastructure, facilities and elements is conducted annually through a list of priorities established through the County's Multi-Year Accessibility Plan, in conjunction with the Accessibility Advisory Committee. The County intends to implement these accessibility standards to the greatest extent possible, for all renovations and alterations to facilities, sites and elements of the built environment.



EXTERIOR STANDARDS

Parking

How the Standard applies

This section applies to accessible parking spaces provided for the following types of exterior or interior parking facilities:

- parking garages or related structures (e.g., above or below grade);
- surface parking;
- on-street parking;
- off-street parking facilities that are not located on a barrier-free path of travel, regulated under Ontario’s Building Code; and
- off-street parking facilities that are part of multiple facilities on a single site where appropriate accessible parking is provided elsewhere on the same site.

Exception(s): The described standards do not apply to off-street parking facilities that are used exclusively to park the following types of vehicles:

- buses;
- delivery vehicles;
- law enforcement vehicles;
- medical transportation vehicles, such as ambulances; and
- impounded vehicles.

STANDARDS

Parking Spaces

1. Accessible parking spaces are required wherever parking is provided. The County will only provide **Type A** spaces (minimum 3,400 mm wide) consisting of a wider parking space which accommodate larger vehicles such as vans that are equipped with transfer ramps for users of wheeled mobility aids
2. Section 5.5.1 in the *Haldimand County Zoning By-Law* defines the total number of required accessible parking spaces according to lot size as shown in Table 1 below

Table 1: Total Number of Required Accessible Parking Spaces

Total Number of Required Parking Spaces	Minimum Number of Type A Accessible Parking Spaces
1 to 12	1
13 to 100	4% total
101 to 200	1 + 3% total
201 to 1000	2 + 2% total
Over 1000	11 + 1% total

Number of spaces is to rounded up to the nearest whole number

3. where a parking facility serves multiple buildings or accessible entrances, distribute accessible parking spaces to enable users to park near as many accessible entrances as possible
4. Where more than one parking facility is provided at a site:
 - o ensure the number of accessible parking spaces provided is determined based on the total number of parking spaces required for each of the separate parking facilities
 - o locate and distribute accessible parking spaces among the off-street parking facilities in a manner that provides substantially equivalent or greater accessibility in terms of distance from an accessible entrance or user convenience (e.g., protection from weather, lighting, security and comparative maintenance)
5. Where the parking facility is a multi-level parking facility, ensure the accessible parking spaces are easy to identify and have at least one accessible route leading to an entrance, exit or elevator lobby
6. Accessible parking spaces and adjacent access aisles should be regularly maintained, kept clear of debris and snow, and where possible, have overhead protection for users from the elements (e.g., such as direct sun, rain or snow)
7. Avoid having the accessible route cross through a drive aisle. Pedestrians should not have to travel behind parked vehicles or move along roadways. Ensure any pedestrian crossing or travel area is clearly marked so it is visible to drivers and pedestrians
8. Where spaces are configured such that the front or rear of parked vehicles is immediately adjacent to a pedestrian walkway, consider a design that prevents vehicle overhangs which could reduce the width of the walkway

9. Provide additional vertical height clearance of 2.8 m (min.) to accommodate larger vehicles



Haldimand County Target Objective: Minimum, four percent (4%) of the total number of parking spaces to be accessible. Where facilities may expect a higher proportion of people with disabilities using their services (e.g., Seniors' Centres, Long Term Care and other medical facilities), the provision of additional accessible parking spaces is to be determined on a case-by-case basis. The appropriate number of spaces may be based off of the expected usages.

Parking Design and Layout

1. Ensure accessible parking spaces are located within 30 m (maximum) from accessible entrance(s)
2. Locate accessible parking spaces as close as possible to an accessible entrance and integrate with an accessible route; where not possible there will be a 2 m wide accessible route delineated to the access of the building
3. Ensure ground surface is firm, stable and slip-resistant
4. Maximum running slope of surface at 1:50 (2%)
5. Maximum cross-slope of surface at 1:50 (2%)
6. Length of 5.2 m
7. Provide an access aisle adjacent and parallel to each accessible parking space:
 - 1.5 m wide (minimum)
 - extend the full length of the space
 - clearly indicated by high colour contrast diagonal pavement markings
 - where two accessible parking spaces are provided adjacent to each other, they may share an access aisle
 - connect with adjacent accessible path of travel and centre curb ramp on access aisle
8. Ensure vertical height clearance of 2.1 m (minimum) at designated parking spaces and along the vehicle access and egress routes
9. Provide lighting in accordance with Lighting requirements, as applicable

Signage and Pavement Markings

Vertical Signage

1. Mark with International Symbol of Accessibility
2. Ensure size of 300 mm wide by 600 mm high (minimum)
3. Mount at height of 1.5 m to 2 m (centre) (e.g., wall or post-mounted), from ground /floor
4. Ensure a high tonal contrast is provided between sign and background environment
5. Provide information text, compliant with County By-law requirements

Pavement Markings

1. Mark with International Symbol of Accessibility
 - Ensure 1,525 mm wide by 1,525 mm depth (minimum)
 - Provide a white or yellow border with a blue background field colour
 - Locate near the back of the space for 90 degree or angled parking spaces and centred for parallel parking spaces
2. Ensure all pavement markings are slip resistant and clearly visible through use of high tonal contrast compared to the surface of the parking space.

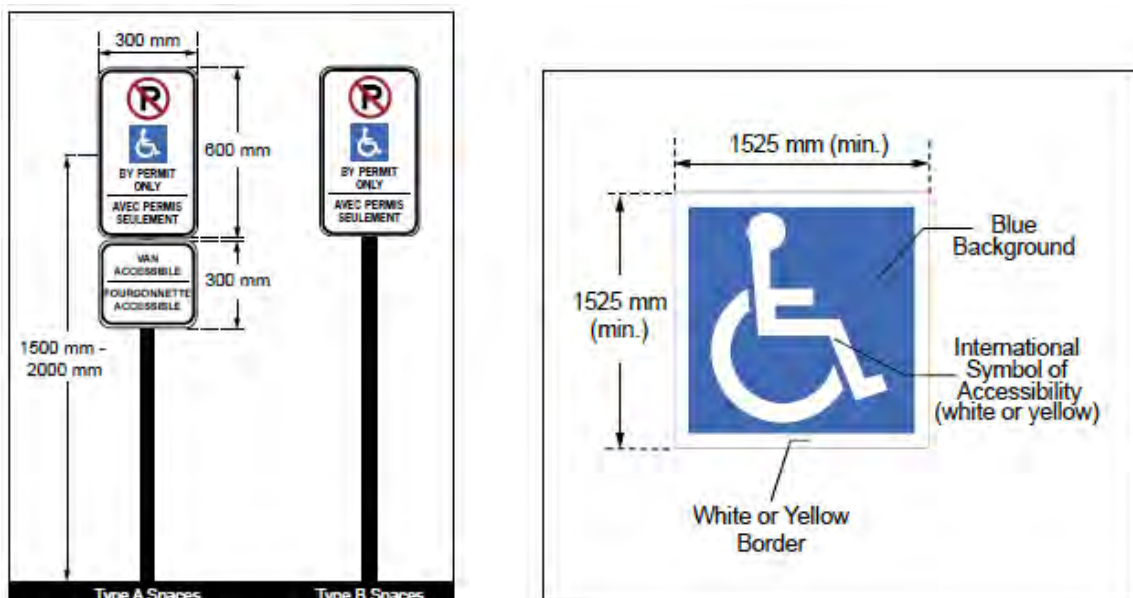

Figure 1: Examples of parking signage

On-Street Parking

When constructing new or redeveloping existing on-street parking spaces, consultation on the need, location and design of accessible on-street parking spaces must occur with the Haldimand County Accessibility Advisory Committee.

Exterior Paths of Travel

How the standard applies

This section applies to exterior paths of travel, which typically include, but are not limited to:

- pedestrian circulation routes that serve as connections between the property line/site boundary of a facility, or at facility entrances, exits, elements or amenities;
- public rights-of-way (e.g., sidewalks, trails and walkways);
- ramps; and
- curb ramps.

STANDARDS

General standards for Exterior Paths of Travel

1. ensure ground surfaces are firm, stable and slip-resistant
2. provide adequate drainage to prevent water accumulation
3. ensure headroom clearance is not less than 2.1 m
4. provide lighting in accordance with lighting requirements, as achievable
5. where a pedestrian route crosses or joins a vehicular route and the walking surfaces are not separated by curbs, railings or other elements between the pedestrian and vehicular areas, provide tactile walking surface indicators (TWSI), continuous along the full length of the crossing boundary

Sidewalks

1. Ensure a minimum sidewalk width of 1.5 m
 - Sidewalks in subdivisions or within urban boundaries will conform to the Ontario Provincial Standards Drawing (OPSD) standards
2. All public parks and private parks will have a minimum sidewalk width of 1.5 m
 - Sidewalks in public parks and private parks will conform to the OPSD standards

Trails

1. Ensure a minimum trail width of 1.5 m
2. Have a firm and stable surface, e.g. compacted stone dust, asphalt pavement, concrete
3. Have a minimum height clearance of 2.1 m
4. Have rest areas available every 110 m on urban trails located within county parks
5. Have rest areas available every 500 m to 750 m on naturalized trails where achievable
6. Rest area shall have a bench and an area for mobility devices
7. Rest area shall be a concrete slab, see Figure 34
8. Shall be designed to drain surface water away



Walkways

1. Ensure a minimum walkway width of 1.5 m
2. Surface will be constructed out of asphalt or other similar material (no engineered wood shavings permitted)
3. Path of travel will be consistent surface material
4. Have a minimum height clearance of 2.1 m
5. Shall be designed to drain surface water away
6. Walkways shall start within proximity of the barrier free parking and extend through the parkway
7. Rest areas as per park design and will be evaluated on a case-by-case basis



Haldimand County Target Objective: For all paths of travel, where feasible, it is always preferred to increase the width of the path of travel from the minimum 1.5 m to at least 1.8 m or greater. This allows for easier accesses for mobility aids, strollers, etc. as well allows for a safer mixed-use user experience.

Curb Ramps and Depressed Curbs

Curb ramps and depressed curbs are required when there is a change in level between exterior path of travel and adjacent vehicular route.

The provision of curb ramps and depressed curbs ensures a continuous accessible path of travel between vehicular and pedestrian routes, for the following typical locations:

- pedestrian crossings at intersections;
- parking spaces, passenger loading zones and related access aisles; and
- any other exterior pedestrian route where there are elevation changes.

The choice between providing a curb ramp or a depressed curb depends on physical characteristics, volume of pedestrian traffic and space availability. The flared sides of the curb ramps provide additional directional assistance, however, having a raised curb between curb ramps may not be suitable to high pedestrian traffic locations, or possible due to intersection geometry, and therefore a depressed curb may be chosen.

It can be very difficult for people with visual disabilities to orient themselves relative to the crosswalks at very large depressed corners. Instead of a fully depressed corner, consider providing a full height curb around the corner radius with appropriate transitions from the separate depressed curbs or curb ramps at each crosswalk. Landings shall be permitted to overlap other landings and clear space.

Design and Layout

1. Refer to OPSD standards for requirements

Landing

Ensure a level landing of 1,200 mm by 1,200 mm (minimum) is provided at the top of the curb ramp, see *Figure 2* below.

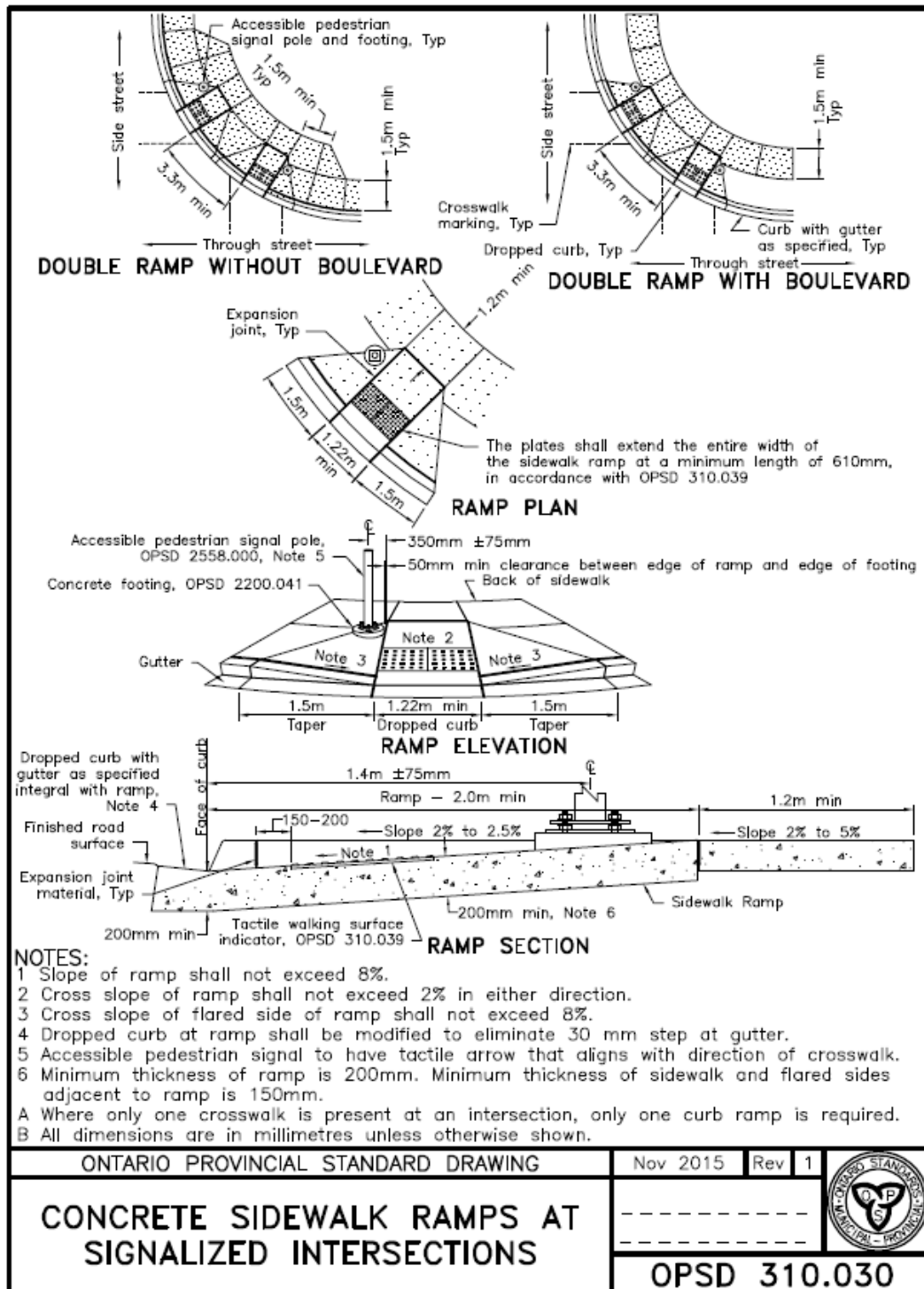

Figure 2: Concrete Sidewalk Ramps at Signalized Intersections

Tactile Walking Surface Indicators (TWSIs) at Curbs Ramps and Depressed Curbs

Where curb ramps or depressed curbs are provided on an exterior path of travel, provide tactile walking surface indicators in accordance with the Common Elements section on Tactile Walking Surface Indicators and also the following:

1. Install at the bottom portion of the curb ramp or depressed curb, set back 150-200 mm from the back edge of the curb, and following any curvature in the curb
2. Install in concrete and with a minimum 150 mm concrete border around the TWSI for locations within a non-concrete sidewalk or walkway
3. Install with the tops of the domes level with the adjacent concrete surface
4. Have drainage cuts from the lower corners and other low points of the TWSI to the curb
5. Have a minimum depth of 610 mm
6. For curb ramps, ensure TWSI extend along the full width of the curb ramp;
7. For depressed curbs, ensure TWSI extend along the bottom portion of the depressed curb that is flush with the roadway, and to a minimum width of 1500 mm; and
8. For depressed corners where two pedestrian crossings are provided, ensure the TWSI extend around the corner wherever the bottom portion of the curb is flush with the roadway, providing a 300 mm space (gap) in the TWSI located at the junction where the two crossings meet.



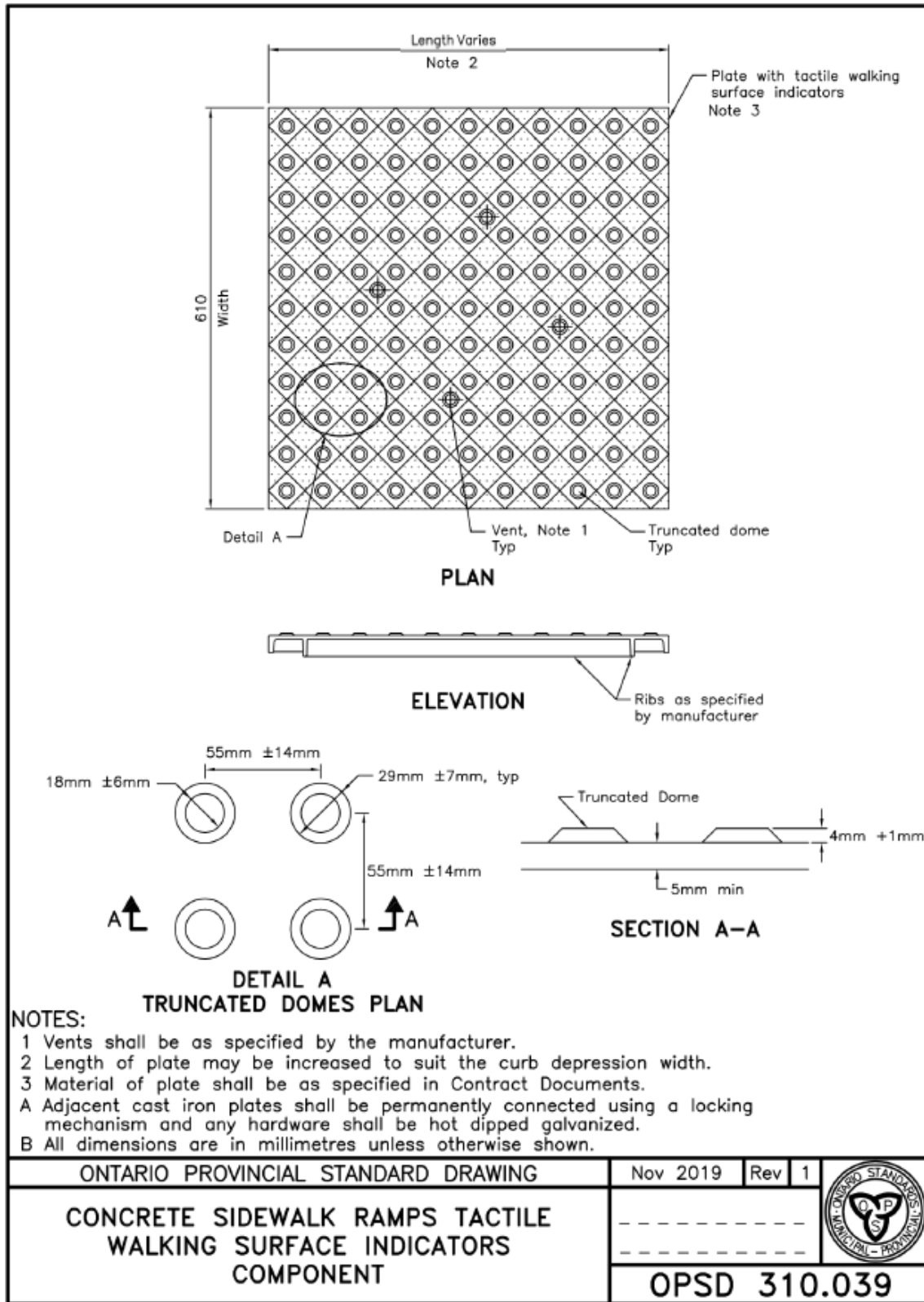

Figure 3: Tactile Walking Indicator Diagram



INTERIOR

Entrances

How the standard applies

This section applies to pedestrian entrances into facilities, building and structures, including the main entrance. An entrance typically consists of several elements such as the approach and route leading to a facility, the components of the entrance itself and transition area between exterior and interior environments (e.g., vestibule). It may also include an interior lobby or waiting area, where applicable.

STANDARDS

General standards for Entrances

1. At least one main or primary entrance into a facility is required to be accessible (e.g., via level, sloped or ramped accessible routes)
2. Locate entrance 30 m or less from designated accessible parking or passenger loading or drop-off zones

Main or Primary Entrance Features

Where an entrance is designated as a main or primary accessible entrance into a facility, adhere to the following standards:

1. Locate as part of an accessible path of travel, including exterior level landing area of 1,670 mm by 1,670 mm (minimum)
2. Provide a power door operator and mark door with International Symbol of Accessibility
3. Provide directional signage at strategic points to guide users from accessible parking areas, drop-off and loading zones, and site access points to the accessible entrance
4. Ensure clear door width of 860 mm (minimum)
5. Where an entrance vestibule is provided, ensure:
 - the distance between the two doors in series is 1,500 mm (minimum), plus the width of the door swinging into the space; or
 - a turning space of 1,500 mm (minimum) diameter is provided where doors do not align

6. Where overhead protection (e.g., canopy) at pedestrian entrance and passenger loading or drop-off zones adjacent to the entrance is provided, ensure the height clearance is 2750 mm



Haldimand County Target Objective: For main entrances to larger facilities with high-occupancy load, an automatic sliding door system is recommended to control the flow of pedestrian traffic and facilitate access for the majority of users.

Doors and Doorways

How the standard applies

This section applies to all interior and exterior doors along an accessible route, intended for staff and public use, which lead into, out of and through a facility. The provision of accessible doors as part of an accessible route is an important consideration for all users of a facility.

Where doors have more than one independently operated leaf (e.g., at a bank of doors), at least one of the doors is required to be accessible, meeting the criteria identified in this section.

STANDARDS

Clear Width

For interior and exterior doors and doorways along an accessible route:

1. Provide a clear width of 860 mm (minimum), measured when the door is open 90 degrees from the face of door (and/or exit door hardware that projects into the path of travel) and the opposite door stop
2. Where there is a projection into clear opening width, ensure it is 100 mm (maximum), no lower than 865 mm high above floor

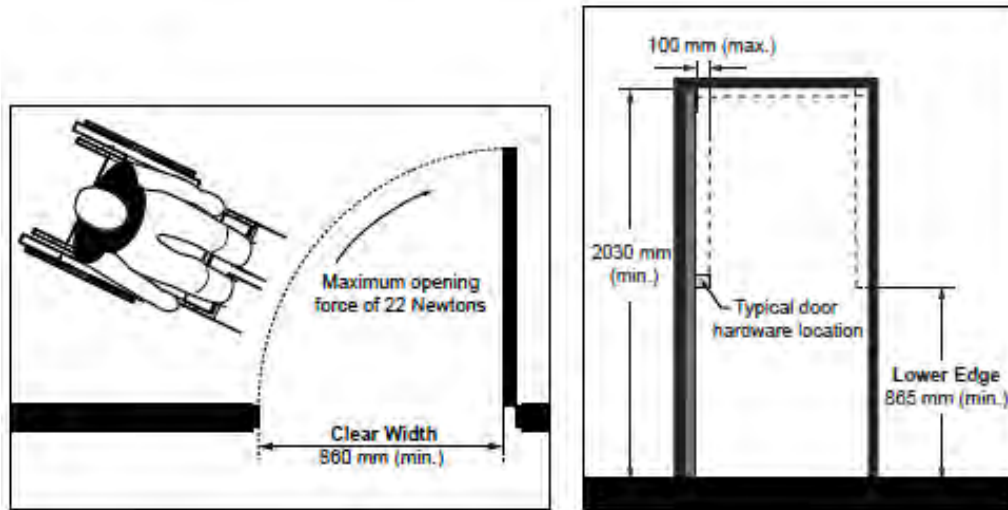

Figure 4: Example of clear door widths

Thresholds

1. Provide bevel at maximum slope of 1:2 (50%), where transition is between 6 mm and 13 mm high; and
2. Ensure threshold at door is not more than 13 mm high.

Door Hardware

Door hardware includes, but is not limited to, handles, pulls, latches and locks, and must adhere to the below standards:

1. Mount between 900 mm (minimum) and 1,100 mm (maximum) high from finished floor or ground surface
2. Hardware must be usable with closed fist and operable with one hand
3. Ensure tight grasping of hands, pinching of fingers or twisting of wrists are not required to operate hardware
4. Ensure high tonal contrast hardware finishes are provided when compared to mounting surface.

Automatic Doors

Where automatic doors are provided, which are sliding or swinging doors activated by infrared sensors:

1. Ensure sensors are suitably placed to detect users approaching; and
2. Ensure timing allows safe passage through doors.

Power-assisted Doors

Power-assisted doors have two different types of operation:

- automatically activated by a motion detector or a floor pad sensor; and
- manually activated by pushing a control.

Power-assisted swing doors that are activated by pushing a control or automatically activated doors by a floor pad or sensor are required at the main entrance(s). A manually activated power-assisted door is required for every accessible washrooms of a facility.

Doors that open automatically are considered a preferred option where possible, since they do not require manual activation and address the needs of a wide range of users. This recognizes that manual power-assist controls may be difficult to locate and activate for people with limited vision, strength, manual dexterity, reach or users that may have multiple types of disabilities.

Based on the overall design, the level of use of interior spaces and where swing doors are provided throughout a facility, power-assisted swing doors that are activated by pushing a control are also commonly provided at:

- interior doors along accessible routes and/or connecting accessible routes;
- doors into reception areas;
- doors into highly used functional spaces (e.g., larger multi-purpose rooms, meeting or board rooms); and
- doors leading to accessible exits and designated "Areas of Refuge".

Where power-assisted swing doors activated by pushing a control are provided:

1. Mark accessible doors with International Symbol of Accessibility and other signage (e.g., "Caution" decals to warn of door swing)
2. Ensure a force of no more than 66 Newtons is required to stop door movement
3. In case of power failure, ensure power-assisted doors can be opened manually
4. Ensure door remains fully open for 5 seconds (minimum)

5. Ensure doors take 3 seconds (minimum) to move from a closed to fully open position, when activated
6. Provide power door operator controls on both sides of doors, for use when entering or leaving, with the following criteria:
 - mount in clearly visible location for easy identification upon approach on the latch side
 - ensure the dimension of the power door operator control is 150 mm (minimum) in diameter where it is circular or 150 mm wide by 915 mm long (minimum) where it is a vertical extended power door operator
 - ensure high tonal contrast is provided between power door operator control and mounting surface
 - ensure they project less than 100 mm from mounting surfaces
 - mark with International Symbol of Accessibility
 - ensure controls are operable with a closed fist
 - mount at height of 900 mm to 1,100 mm from ground or floor surface
 - where rectangular extended power door operator controls are provided, mount so that they extend from not more than 200 mm and not less than 900 mm high above the floor
 - mount between 600 mm on a level wall surface or separate post, beyond the door swing where the door opens towards the control
 - provide a minimum clear floor space of 1,675 mm by 1,675 mm in front of power door operator control

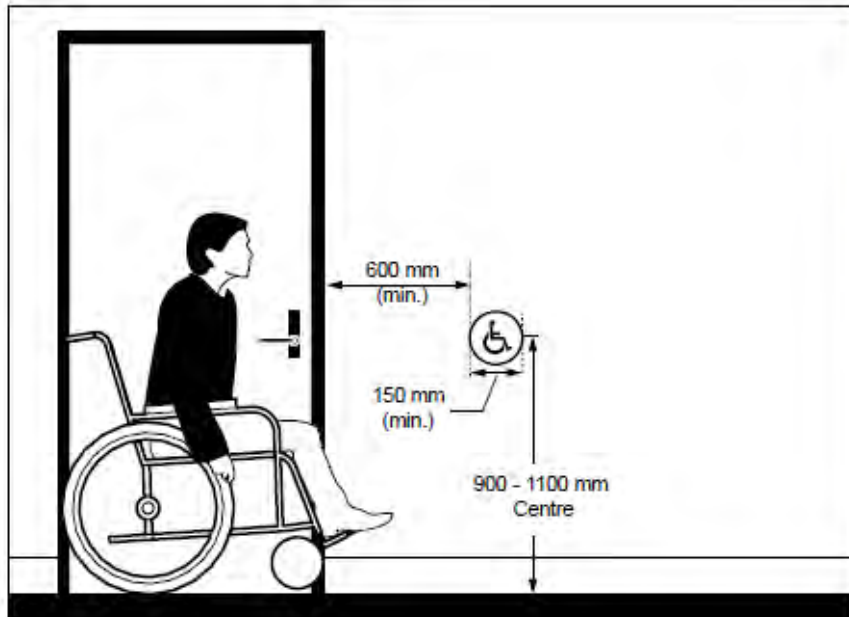

Figure 5: Example of power door button mounting locations



Example of circular power door operator control.

Doors Swinging into Accessible Routes

Where automatic or power-assisted doors (whether activated manually by a control or automatically by a motion sensor or a floor-pad sensor), swing into an accessible path of travel, adhere to the below standards:

1. Provide recessed doors wherever possible
2. For swinging doors opening into passing pedestrian traffic, provide cane detectable guards or other devices at right angles to the wall containing the door, with the lower rail surface mounted no more than 680 mm high (maximum) from ground or floor surface, extending 300 mm (minimum) beyond the door swing, on both sides of doors.

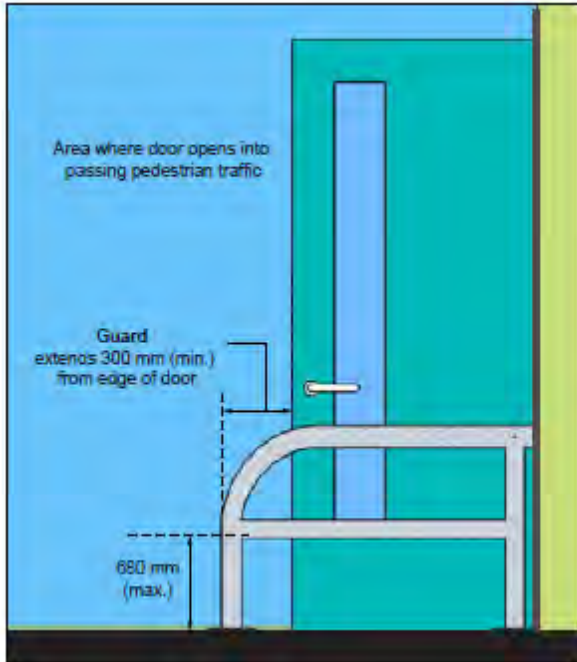

Figure 6: Example of a guard at door

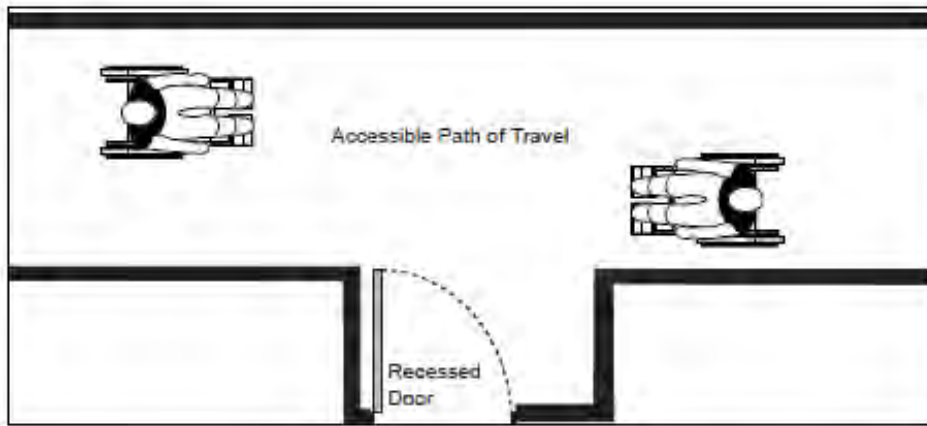

Figure 7: Example of a recessed door

Approach Clearances at Doors

The floor space requirements at swinging doors are dependent on the door’s approach (e.g., side or front) and on which side an individual approaches a door (push or pull sides). Clear floor space requirements for approach at different types of doors are summarized in the table and figures below.

Table 2: Approach Clearances at Doors

Context	Floor Space Required in mm		
	Depth (min.)	Width (min.)	Space Beside Latch
Side-Hinged Door – Front Approach (fig. 8)			
Pull side	1,525	1,600	600
Push side	1,370	1,250	300
Sliding Door (fig. 9)			
Front approach	1,370	1,100	300
Side approach	1,370	1,550	600
Side-Hinged Door – Hinge Side Approach (fig. 10)			
Pull side	1,600	1,600	600
Push side	1,370	1,830	450
Side-Hinged Door – Latch Side Approach (fig. 11)			
Pull side	1,370	1,600	600
Push side	2,370	1,525	600
Folding Door			
Front approach	1,220	n/a	n/a
Side approach	1,220	n/a	n/a
Recessed Door – Front Approach (fig. 12)			
Pull side	1,525	n/a	450
Push side	1,220	n/a	300
Doorways Without Doors			
Front approach	1,220	n/a	n/a
Side approach	1,065	n/a	n/a

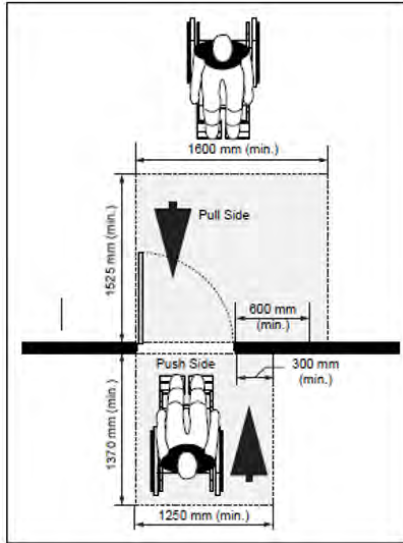

Figure 8: Side-Hinged Door - Front Approach

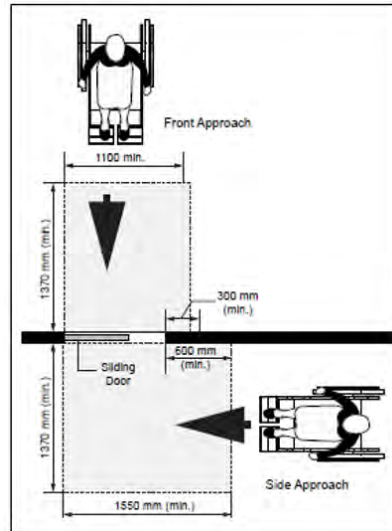

Figure 9: Sliding Door

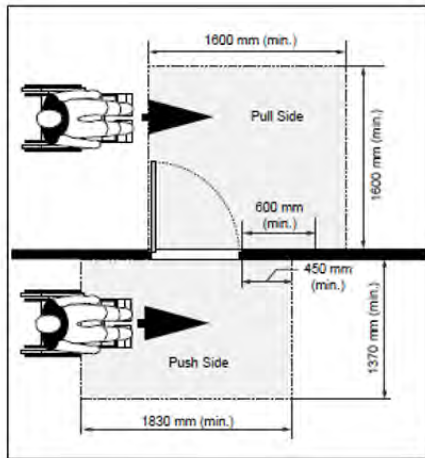

Figure 10: Side-Hinged Door - Hinge Side

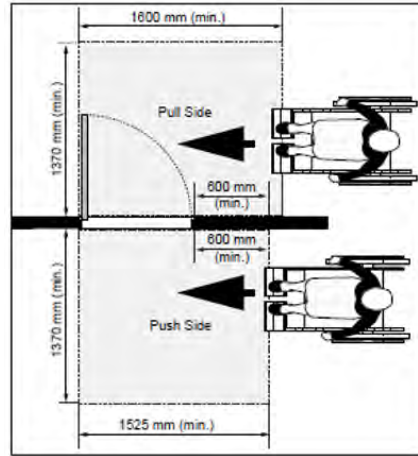

Figure 11: Side-Hinged Door - Latch Side

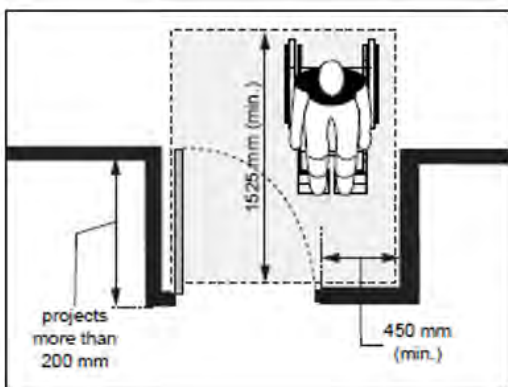
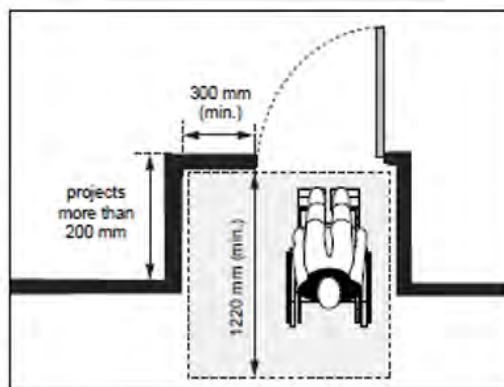

Figure 12: Recessed Door - Front Approach



Doors in Series

Where doors in series form a vestibule:

1. Provide a distance between two doors in series of 1,500 mm (minimum), plus the width of the door swinging into the space
2. Where the doors into the vestibule are not aligned, provide a turning diameter of 1,500 mm within the vestibule clear of any door swing
3. Arrange vestibule to allow the movement of users of mobility aids between doors

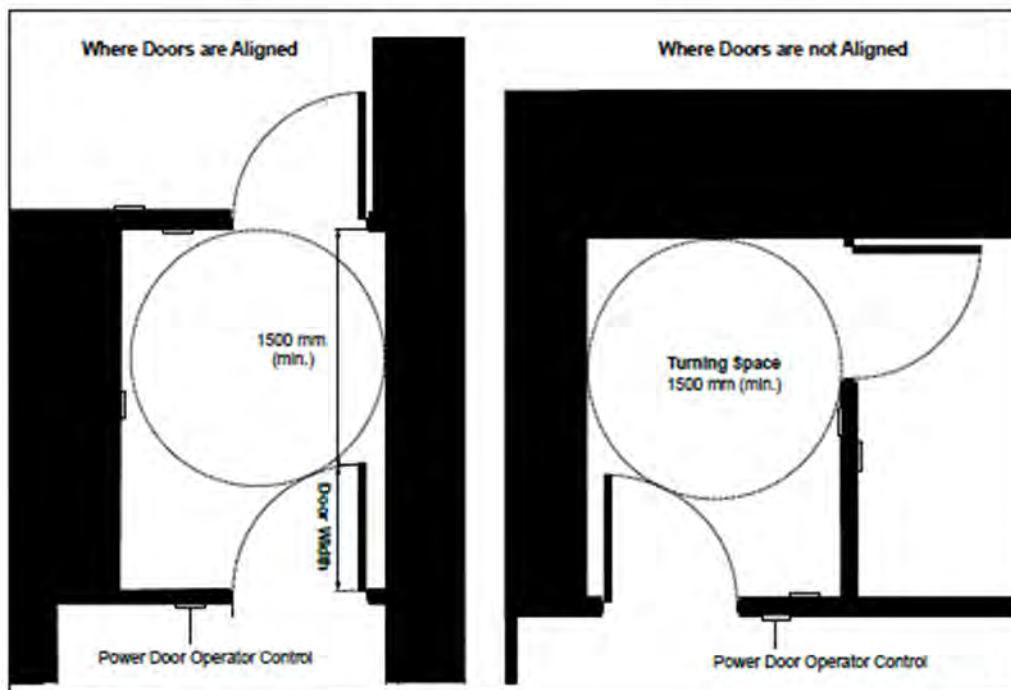

Figure 13: Turning radius between doors



Haldimand County Target Objective: Provide power door operators for high frequency doors (e.g., large meeting/multipurpose rooms) in new construction. Provide roughed in power for future power door operators at other locations.

Interior Accessible Routes

How the standard applies

This section applies to accessible routes or paths of travel for pedestrians within a facility to provide access to elements, rooms or other occupiable spaces. Typical accessible routes are

identified as corridors, hallways and other pedestrian circulation paths. All access to occupiable spaces are to be accessible and conform to this section.

Where there is an elevation change within a path of travel, accessible routes may include ramps, sloped walkways and independently operated elevating devices as permitted (e.g., passenger elevators or lifts).

STANDARDS

General Standards for Accessible Routes

1. Ensure floor surfaces are stable, firm and slip-resistant
2. Provide signage and wayfinding cues along interior accessible routes, including entrances and exits, to provide information and guidance for all users based on the type of facility
3. Provide headroom clearance of 2.4 m (minimum)
4. Design public corridors to facilitate wayfinding by using architectural treatments and elements that can be used to differentiate main corridors from secondary corridors
5. Provide lighting in accordance with Lighting requirements, as applicable

Clear Width

1. Provide clear width of 1,100 mm (minimum);
2. In high traffic areas, provide clear width of 1,500 mm (minimum);
3. Where clear width is reduced to 920 mm (minimum) for short indentations up to 600 mm (maximum), provide clear width of 1,100 mm (minimum) beyond indentation and ensure indentations or reduced clear width is not repeated in a series; and
4. Where an accessible route makes a 180 degree turn around an obstacle that is less than 1200 mm wide, ensure clear width of 1,100 mm (minimum) is provided, when approaching and leaving the turn, and 1,200 mm (minimum) at the turn

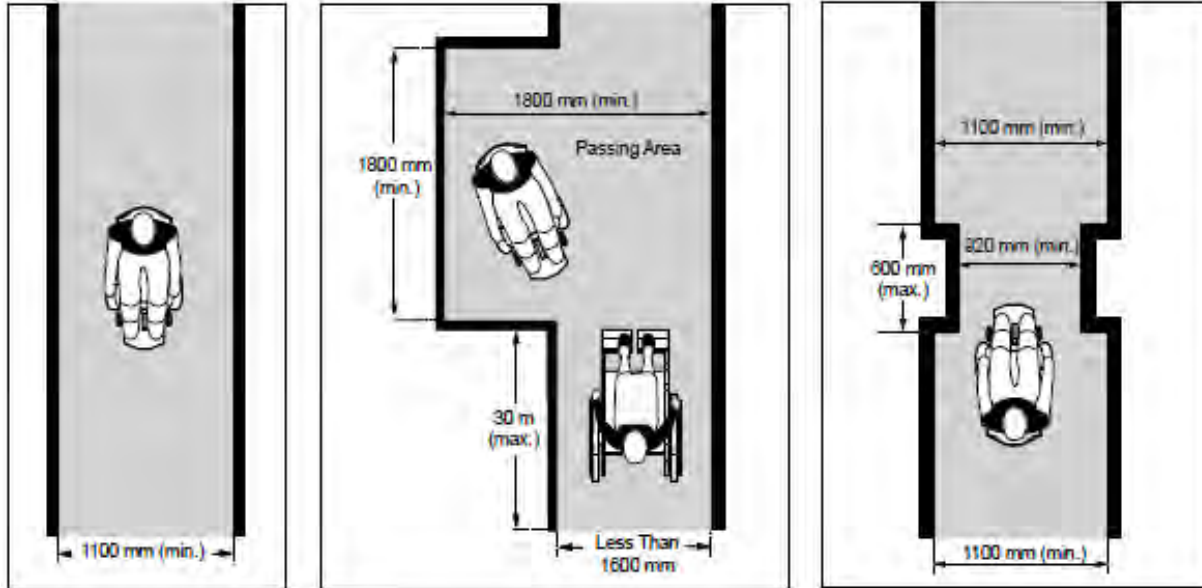

Figure 14: Accessible routes width requirements

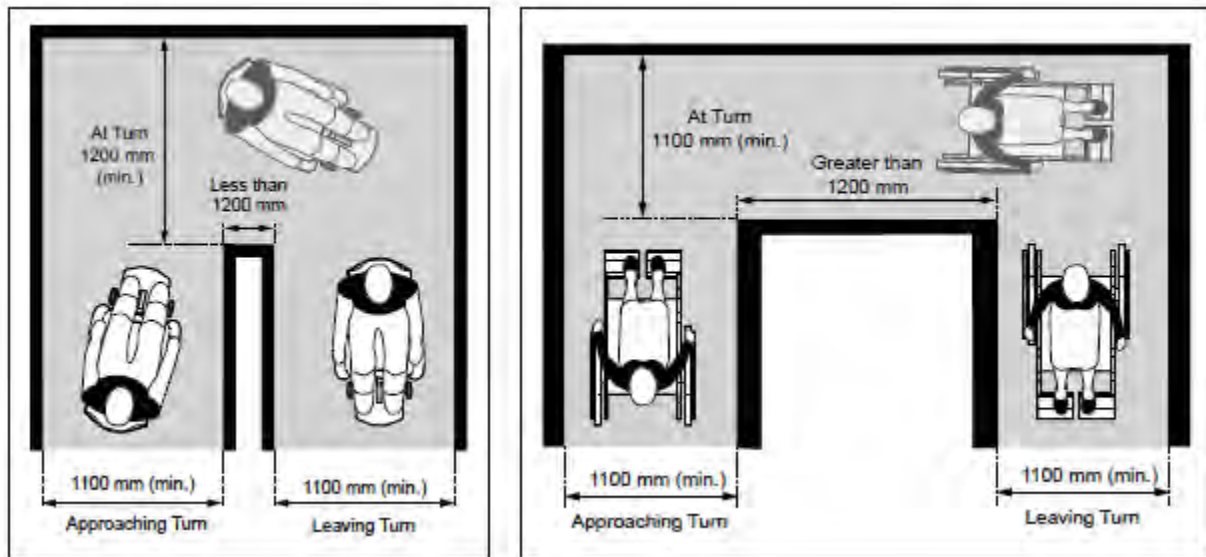

Figure 15: Width requirements for turning

Washrooms

How the standard applies

This section applies to washroom facilities and elements within a site and facility including, but not limited to:

- multiple-occupancy washrooms;
- universal washrooms;

- change rooms with washroom features; and
- unisex washrooms.

If retrofitting multiple occupancy washrooms with accessible water closet stalls is not possible, identifying additional space for providing a universal washroom is required.

Universal washrooms allow the greatest flexibility, including larger floor space for people who require assistance and may be accompanied by a caregiver or companion, as well as to accommodate larger mobility aids such as power wheelchairs and scooters.

STANDARDS

Provision and Locations

1. Provide universal washrooms in accordance to Table 3
2. Provide minimum number of accessible water closet stalls per washroom in accordance to Table 4
3. Locate centrally within a facility along an accessible route, within 45 m (maximum) of regular washrooms
4. Where washrooms are not accessible, provide directional signage to indicate location of nearest accessible washroom on the same floor

Table 3: Minimum Number of Required Universal Washrooms

Number of Storeys in Building	Minimum number of Universal Washrooms per Building
1-3	1
4-6	2
More than 6	3, plus 1 for each additional increment of 3 storeys in excess of 6 storeys

Table 4: Minimum Number of Accessible Water Closet Stalls

Number of Water Closets per Washroom	Minimum Number of Accessible Water Closet Stalls per Washroom
1-3	0, where a universal washroom is provided on the same floor within 45 m of the washroom, or

	1, where a universal washroom is not provided on the same floor within 45 m of the washroom
4-9	1
10-16	2
17-20	3
21-30	4
More than 30	5, plus 1 for each additional increment of 10 water closets per washroom in excess of 30 water closets per washroom

Where one water closet is required for males and one water closet is required for females, the following may be provided:

1. One universal washroom; AND
2. One washroom containing one water closet to be used by both sexes provided the door to the room can be locked from the inside.

Multiple Occupancy Washrooms

For multiple occupancy washrooms with accessible water closet stalls:

1. Identify clearly with signage, indicating male or female where applicable, with other accessibility features (e.g., braille, tactile, International Symbol of Accessibility, etc.)
2. Where doors are provided at washroom entrance, provide a clear width of 860 mm (minimum), when the door is in the open position and equip with power door operators
3. Ensure lighting level is evenly distributed in accordance with Lighting Requirements, as applicable
4. Ensure minimum clearance of 1,700 mm between the inside face of an in-swinging entrance door and the outside face of an adjacent water closet stall
5. Ensure minimum clearance of 1,400 mm between outside wall of stall and any wall-mounted fixtures or other obstructions
6. Provide a clear floor space of 1,500 mm by 1,500 mm (minimum) in front of the accessible water closet stall; The stall door is not to interfere with that radius
7. Ensure a clear turning diameter of 1,500 mm (minimum) is provided inside washroom circulation area, 500 mm (maximum) of which may be under the lavatory to allow users of mobility aids to make a 180 degree turn
8. Ensure floor surfaces are slip-resistant, with a maximum slope of 1:50 (2%)

9. Provide accessible lavatories with washroom amenities, as identified in this section
10. Provide accessible water closet stalls with suitable clear floor space, as identified in this section
11. Install audible and visual fire alarm system
12. Install any drains out of the path of travel

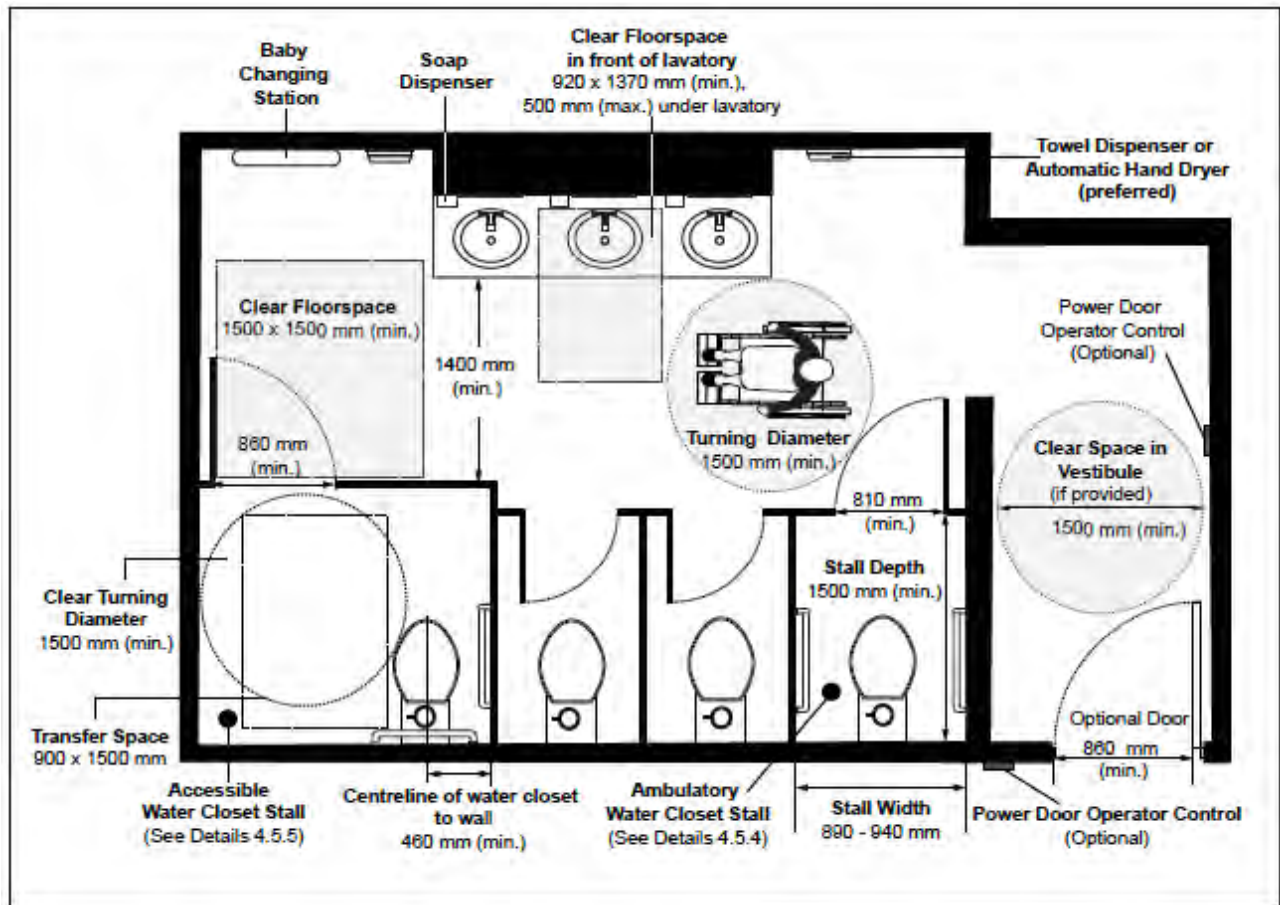

Figure 16: Example of a multiple occupancy washroom

Universal Washrooms

Where universal washrooms are provided:

1. Locate in the same vicinity as other washrooms (e.g., Men's & Women's multiple occupancy washrooms) along the shortest accessible route
2. Identify clearly including unisex pictogram (e.g., Male and Female) and the International Symbol of Accessibility
3. Provide accessible entrance door:
 - ensure a clear width of 860 mm (minimum), when the door is in an open position;
 - equip with power door operator
 - provide locking mechanism that can be locked from the inside and released from the outside, in case of emergency
 - mount graspable operating and locking mechanisms 900 to 1000 mm above floor
 - if it is an outward swinging door, provide door pull 140 mm long (minimum), located on the inside so that its midpoint is between 200 mm and 300 mm from the latch side of the door
4. Ensure internal dimension between walls is no less than 1,700 mm (2,500 mm preferred)
5. Ensure a clear turning diameter of 1,700 mm (minimum) is provided inside the universal washroom
6. Ensure floor surface is firm, stable and slip-resistant
7. Provide one accessible lavatory with other washroom amenities including but not limited to mirror, soap dispenser, paper towel dispenser, automatic hand dryer (preferred), coat hook, and toilet paper dispenser as identified in this section
8. Provide one accessible water closet with suitable rear and side grab bars (e.g., horizontal, L-shaped and fold-down grab bars) as identified in this section
9. Provide motion sensor for automatic illumination of interior
10. Provide lighting in accordance with lighting requirements, as applicable
11. Install audible and visual fire alarm systems
12. Provide a clear floor space 810 mm wide by 1,830 mm long in each universal washroom for an adult-size change table

13. Where the clear floor space provided for an adult-size change table is adjacent to a wall, ensure reinforcement is installed in the wall to permit the future installation of the change table
14. Where an adult-size change table is installed, ensure a clear floor space of 760 mm wide by 1,500 mm long, parallel to the long side of the adult-size change table
15. Ensure drains are installed out of the path of travel
16. Provide an emergency call system with the following features:
 - o consists of visual and audible signal devices both inside and outside of the washroom that are activated by a push control device inside the washroom;
 - o includes an emergency bilingual sign that contains the words "IN THE EVENT OF AN EMERGENCY PUSH EMERGENCY BUTTON AND AUDIBLE AND VISUAL SIGNAL WILL ACTIVATE" in letters at least 25 mm high with a 5 mm stroke and that is posted above the emergency button; and
 - o where facilities have the capacity and where staff is available, ensure the call system is linked to a display panel at a reception/information counter or to a centrally monitored station (e.g., security desk).

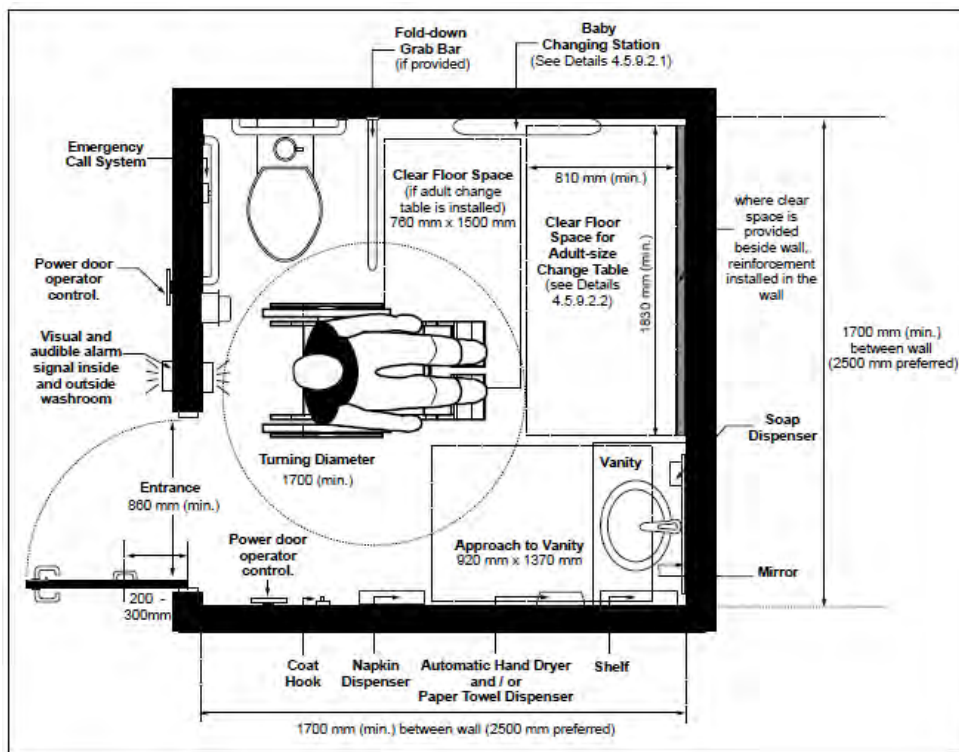

Figure 17: Example of Universal Washroom Design



Haldimand County Target Objective: Install a minimum of 1 adult change table per facility. This allows for a more supportive and inclusive facility.

Accessible Water Closet Stalls

Where accessible water closet stalls are provided in multiple occupancy washrooms:

1. Mark accessible water closet stall with International Symbol of Accessibility
2. Provide a clear turning space of 1,500 mm diameter (minimum)
3. Provide an emergency call system with the following features:
 - a. consists of visual and audible signal devices both inside and outside of the washroom that are activated by a push control device inside the washroom
 - b. includes an emergency sign that contains the words "IN THE EVENT OF AN EMERGENCY PUSH EMERGENCY BUTTON AND AUDIBLE AND VISUAL SIGNAL WILL ACTIVATE" in letters at least 25 mm high with a 5 mm stroke and that is posted above the emergency button
 - c. where facilities have the capacity and where staff is available, ensure the call system is linked to a display panel at a reception/information counter or to a centrally monitored station (e.g., security desk)



Haldimand County Target Objective: Install fold-down grab bars in all accessible water closet stalls.

Stall Doors

1. When door is in an open position, provide clear width of 860 mm (minimum)
2. Ensure the door is aligned with water closet transfer space (e.g., door is positioned on opposite side of water closet)
3. Ensure door swings outward, unless a clear floor area of 820 mm wide by 1,440 mm long (minimum) is provided within the stall or enclosure to permit the door to be closed inside without interfering with the mobility device
4. Provide accessible locking mechanisms, with stall capable of being locked from the inside by a control that is operable with a closed fist
5. Ensure door can be released from the outside in case of emergency

6. Provide D-type door pull on inside and outside of the door:
 - a. ensure hardware provides high tonal contrast with mounting surface
 - b. provide length of 140 mm (minimum)
 - c. mount horizontally 900 to 1,000 mm high from floor, centered 120 to 220 mm from latch side of the door
 - d. mount horizontally on the inside of an out-swinging door, with its centered 200 to 300 mm to 300 mm from the hinge edge

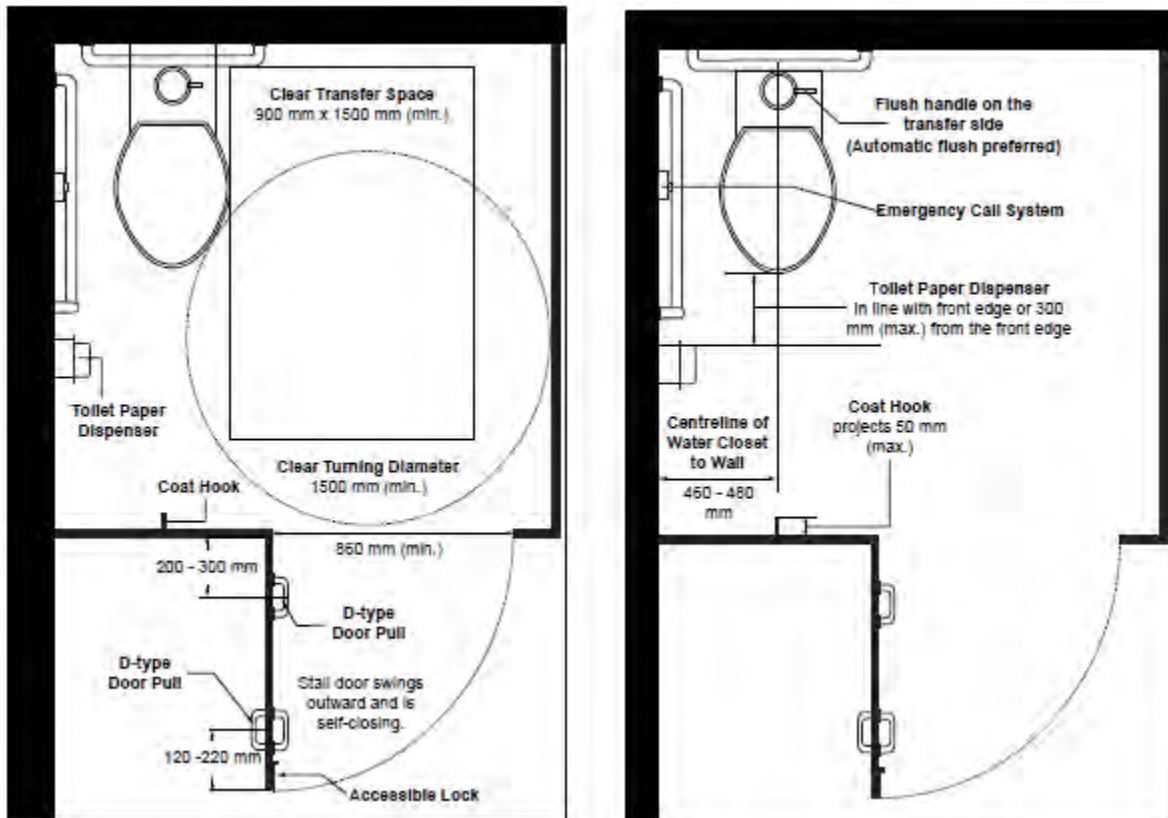

Figure 18: Example of water closet stall features

Water Closets

1. Mount seat between 430 mm and 485 mm high from floor
2. Install water closet so that:
 - o the centreline of water closet from any adjacent side wall is between 460 mm and 480 mm and an unobstructed transfer space of 900 mm wide by 1,500 mm deep (minimum) is provided on the other side of the water closet; or

- a clear transfer space of at least 900 mm wide and 1,500 mm deep is provided on each side of the water closet
- 3. Provide a back support where there is no seat cover/lid or tank, and where there is a tank, ensure tank lid is securely attached
- 4. Ensure seat is not spring activated
- 5. Provide internal extension guards that will not allow the seat to slide
- 6. Mount toilet paper dispenser below the grab bar, 600 to 800 mm high from floor, in line with front edge or not more than 300 mm from the front edge of the water closet
- 7. Install lever flush control or other flush control operable with a closed fist (e.g., push button control) on transfer side
- 8. Install at least one coat hook mounted at 1200 mm (maximum) high from floor, on a side wall and projecting 50 mm (maximum) from mounting surface

Horizontal Grab Bars

1. Ensure length of 600 mm (minimum)
2. Mount between 840 and 920 mm high from floor level, centered behind water closet
3. Where water closet has a water tank, mount grab bar 150 mm above the tank

L-Shaped Grab Bars

1. Ensure length of 760 mm (minimum) for both vertical and horizontal components
2. Mount vertical component 150 mm (maximum) from front of water closet
3. Mount horizontal component 750 mm high above floor

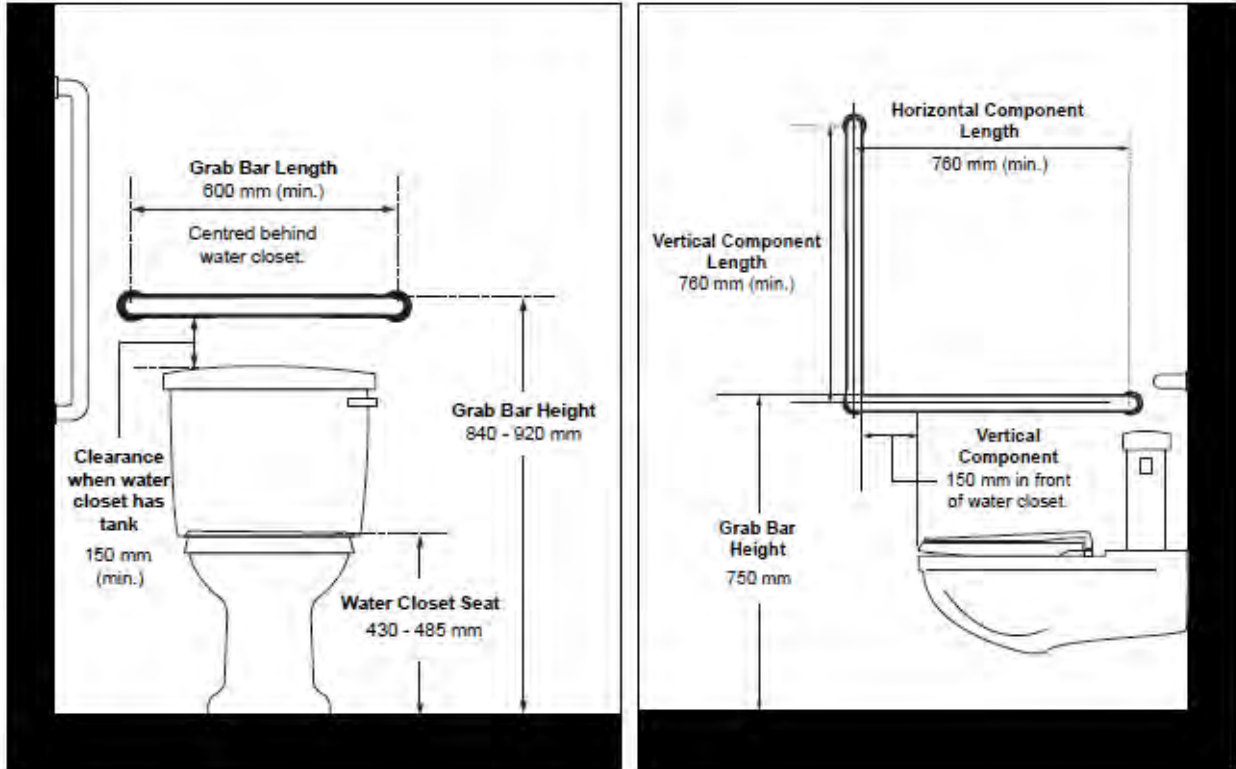

Figure 19: Grab bar mounting requirements

Fold-down Grab Bars

Where fold-down grab bars are provided:

1. Mount on the wall behind the water closet
2. Locate on transfer space side
3. Ensure length of 760 mm (minimum)
4. Mount between 390 mm and 410 mm from centreline of water closet
5. Mount with the horizontal component at 750 mm high from floor level
6. Ensure force required to pull down grab bar is no more than 22 Newtons
7. Where transfer space is provided on both sides of the water closet, provide a fold-down grab bar on each side

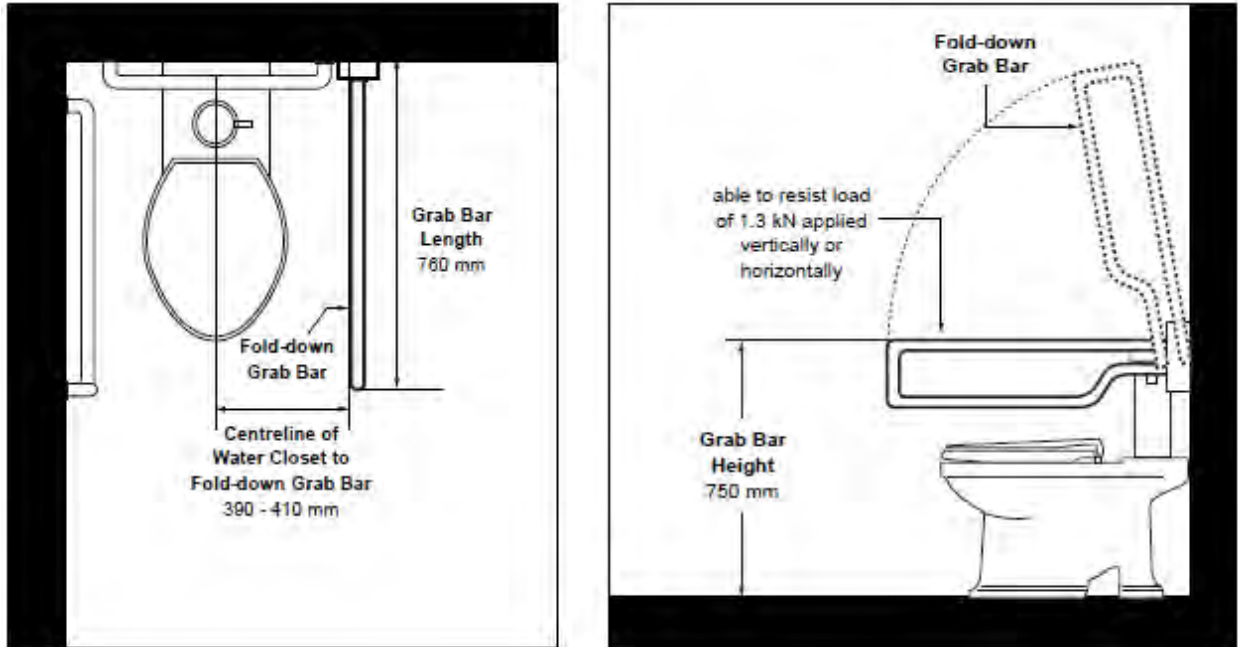

Figure 20: Examples of grab bar designs

Lavatories

The provision of at least one accessible lavatory is required in each accessible washroom facility:

1. Ensure the centreline of lavatory is 460 mm (minimum) from adjacent side wall
2. Ensure top surface is continuous and provides a high tonal contrast with adjacent wall surfaces
3. Mount top surface of lavatory 820 to 840 mm high above floor
4. Provide clearances underneath lavatory no less than:
 - o 920 mm wide
 - o 735 mm high at front edge
 - o 685 mm high at 205 mm back from front edge
 - o 350 mm toe space height from a point 300 mm back from the front edge to the wall
5. Provide automatic control or lever-type faucet without spring loading, located no more than 485 mm depth from edge of basin
6. Mount soap dispenser at 1,200 mm (maximum) high above floor and 610 mm (maximum), measured horizontally from the edge of the lavatory
7. Provide minimum clear floor space of 920 mm wide by 1,370 mm deep (minimum), of which 500 mm depth is allowed under the lavatory

8. Ensure water temperature is controlled to a maximum of 43°C
9. Ensure water pipes are covered or insulated below lavatories

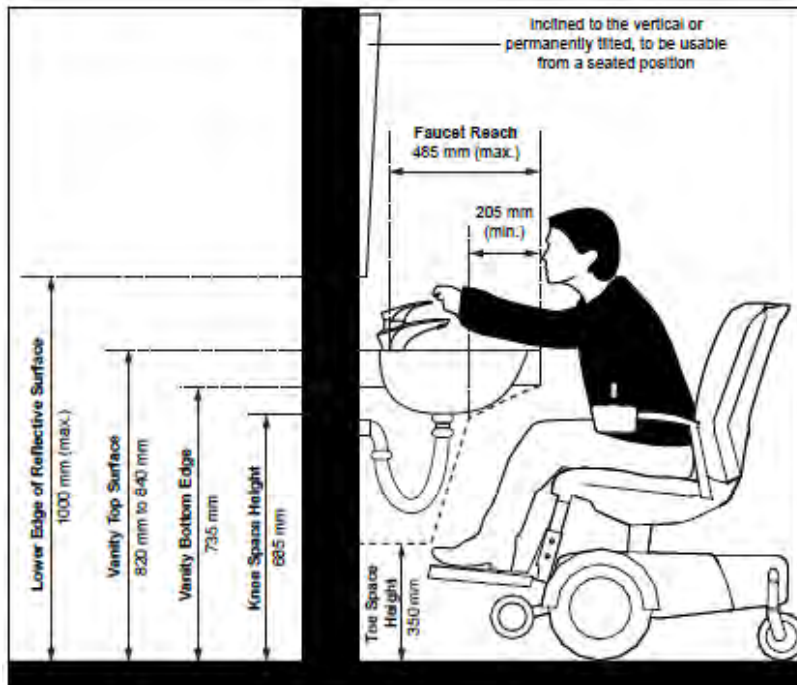

Figure 21: Measurements at a sink

Washroom Amenities

Washroom amenities include, but are not limited to, hand dryers, paper towel dispensers, soap dispensers, waste bins, mirrors, changing stations and tables. Where provided:

1. Ensure wall mounted amenities do not project more than 100 mm from wall along an accessible path of travel
2. Provide high tonal contrast between amenities and mounting surfaces
3. Ensure any operating controls are mounted between 900 mm and 1,200 mm high above floor, operable with a closed fist
4. Ensure the dispensing height of washroom amenities is between 900 mm and 1,200 mm
5. Where amenities are mounted at lavatories (e.g., hand dryers, paper towel dispensers, soap dispensers), install at 1,200 mm (maximum) high, 610 mm (maximum) measured horizontally from the edge of the lavatory
6. Provide minimum clear floor space of:
 - o 920 mm wide by 1,370 mm deep to allow front approach
 - o 1525 mm wide by 920 mm deep to allow side approach

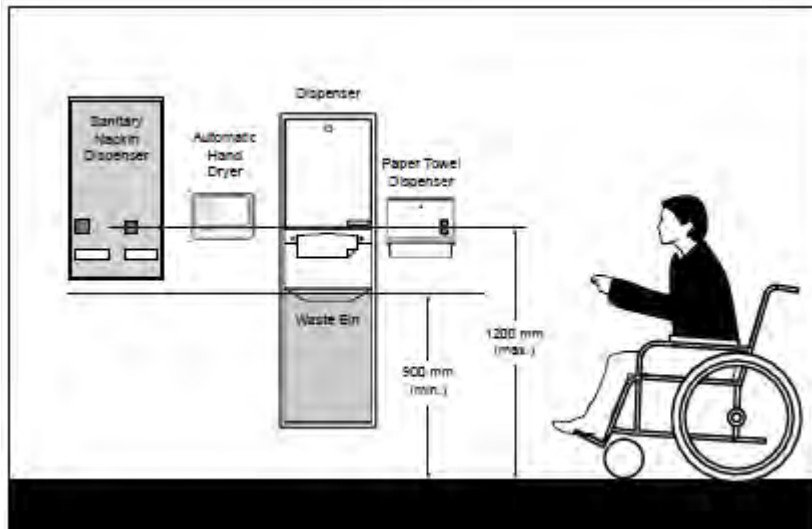

Figure 22: Example of washroom amenities

It is preferred to have a facility that offers a totally hands-free operation for all amenities installed.

Mirrors

1. Mount with the bottom edge of the reflecting surface at 1,000 mm (maximum) high above floor or inclined to the vertical to be usable from a seated position
2. Ensure lighting level over mirrors does not create reflected glare
3. Where full length mirrors are provided, ensure they are not installed where they will reflect path of travel and cause confusion for users

Changing Stations and Tables

Baby Changing Stations

1. Where provided, ensure at least one is accessible for users with disabilities, with unit placed in a location that does not obstruct adjacent paths of travel when in use and positioned in close proximity to a lavatory and waste receptacle
2. Ensure suitable clear floor space of:
 - o 920 mm wide by 1,370 mm depth is provided for a forward approach
 - o 1,525 mm wide by 920 mm depth for a side approach (whether standing or seated) in front of unit
3. Ensure the required floor clearance for changing station does not overlap with floor clearances of other fixtures, when the changing station is folded up

4. Mount with the highest edge or component of the station between 730 and 865 mm
5. Ensure knee clearance of 685 mm high and 480 mm depth is provided
6. Where a folding changing station is provided, ensure projection from wall of 100 mm (maximum) when in folded position and located along accessible path of travel
7. Where a folding-type is provided, ensure operating control:
 - o is mounted no more than 1200 mm
 - o operable with a closed fist and without tight grasping, pinching of fingers or twisting of wrist

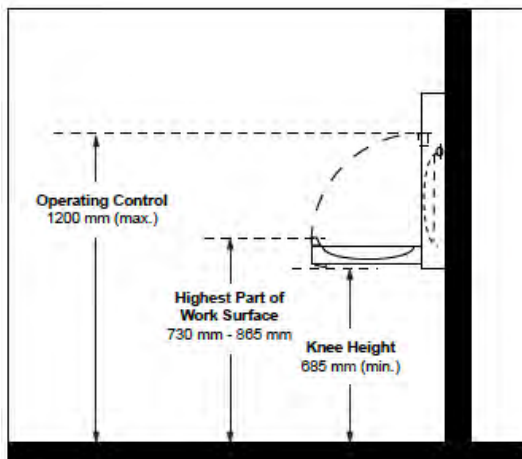

Figure 23: Example of baby change tables



Example of a Baby Changing Station.

Adult-Size Change Tables

Where an adult-size change table is installed in a universal washroom:

1. Provide a clear floor space of 760 mm wide by 1500 mm long (minimum), parallel to the long side of the table
2. When fully loaded, ensure the surface height above the floor is adjustable from between 450 mm and 500 mm at the low range to between 850 mm and 900 mm at the high range
3. Where a fold-down change table is provided:
 - install so that it does not encroach into the clear transfer space adjacent to the water closet
 - ensure operating mechanisms (e.g., latches, handles and pulls) are 1,200 mm high (maximum)
 - ensure operating mechanisms are operable with a closed fist and without tight grasping, pinching of fingers or twisting of wrist
4. Ensure changing tables can support a minimum load of 1.33 kilonewtons
5. Provide a high tonal contrast between change table surface and adjacent mounting surface
6. Ensure change table surfaces are free of sharp edges or abrasive materials, and are easy to clean

Adult-size change tables located in universal washrooms are of benefit to many individuals, and may be used as changing stations or tables. They allow persons with balance or strength problems to sit and allow persons with disabilities to lie down and be changed with the assistance of an attendant, as might be required.

Adult-size change tables are also useful in change rooms, where people are expected to change clothing.

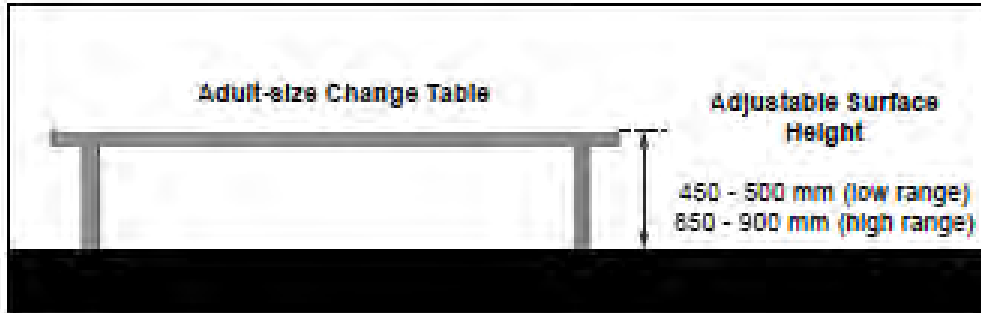

Figure 24: Example of an adult change table

Urinals

Where more than one urinal is provided in multiple occupancy washrooms, provide at least one accessible urinal:

1. Locate within accessible path of travel with no step-in front of the urinal
2. Mount urinal on wall with the lower rim located 430 mm (maximum) above floor, OR provide a floor mounted urinal with the rim level with the floor level
3. Ensure the upper rim is no lower than 860 mm high above floor
4. Ensure depth of 345 mm (minimum), measured from the outer face of the urinal rim to the back of the fixture
5. Ensure urinal has high tonal contrast compared with back wall
6. Provide lever, automatic, or other flush control operable with a closed fist, without tight grasping, pinching or twisting of the wrist (e.g., push button control) mounted 1,200 mm (maximum) high above floor
7. Provide clear floor space of 915 mm wide by 1,370 mm deep (minimum) centered in front of urinal for front approach
8. Provide grab bars, on each side of urinal:
 - mount vertically, with centerline at 1,000 mm high above floor
 - mount 380 mm to 450 mm from centerline of urinal
 - with length of 600 mm (minimum)
 - with high tonal contrast compared to back wall
9. Install centerline indicator for all urinals:
 - centered above the urinal 50 mm wide (maximum)

- extending 1,300 mm (minimum) above floor but never less than 150 mm above the upper urinal rim
- ensure indicator has high tonal contrast compared with back wall and raised 3 mm (minimum)
- where more than one urinal is provided in a washroom, provide a centerline indicator at each urinal

10. Where privacy screens are provided:

- provide clearance of 920 mm (minimum) between screens
- ensure a clearance of 50 mm (minimum) from the grab bars
- ensure colour contrast between screens and surrounding surfaces
- ensure the vertical outer edge provides a high tonal contrast

Placement of privacy screens is dependent on where grab bars are installed. Vertical markers are used to identify centerline of urinal for users with vision loss. Various elements may be used as a centerline indicator, such as exposed piping, architectural features (e.g., raised ceramic tiles), etc.

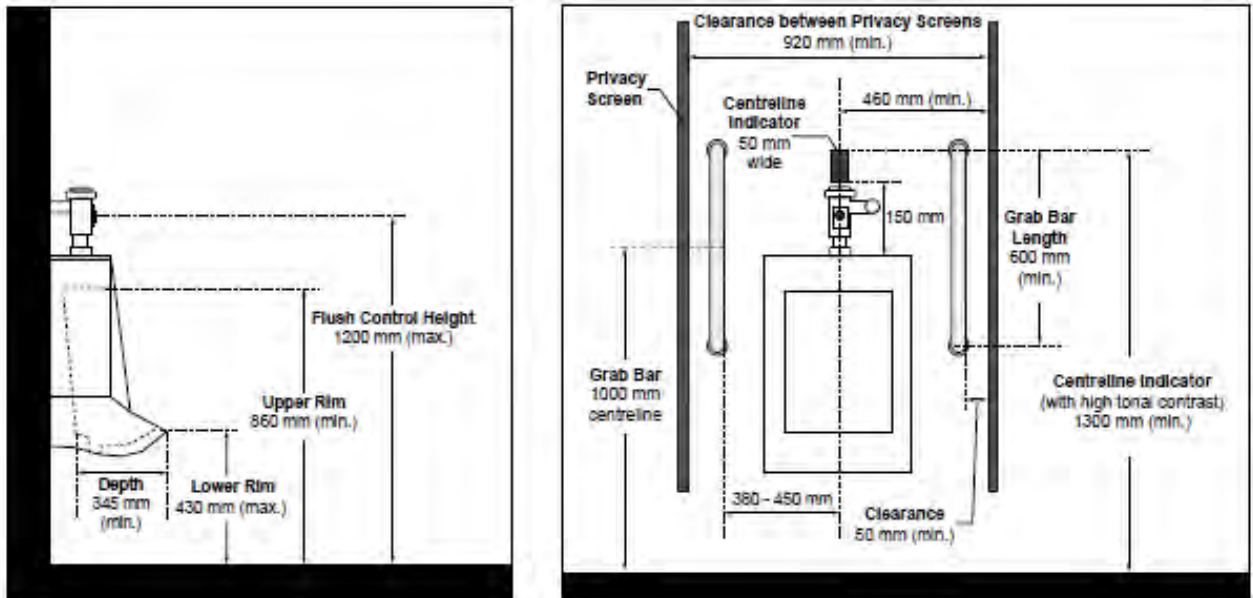

Figure 25: Urinal spacing requirements

Showers

1. Provide at least one accessible shower stall where a group of showers are provided in a facility, as identified below:

Table 5: Accessible shower requirements

Number of Showers provided in a Group	Minimum Number of Accessible Showers Required
1-7	1
More than 7	1, plus 1 for each additional increment of 7 showers in a group

Design and Layout

1. Ensure floor space of 1,500 mm wide by 900 mm deep (minimum)
2. Provide additional clear floor space of 1,500 mm wide by 900 mm deep (minimum) at shower entrance
3. Provide covered trench drain that is suitably located, based on the overall design of the stall and drainage requirements (e.g., preference is for water to drain away from user as much as possible)
4. Ensure level entry or beveled threshold, 13 mm high (maximum)
5. Ensure floor surface is slip-resistant
6. Provide lighting in accordance with Lighting Requirements, as applicable

Where enclosure screens or curtains are provided, ensure mounting provisions do not obstruct transfer from mobility aids to shower seat.

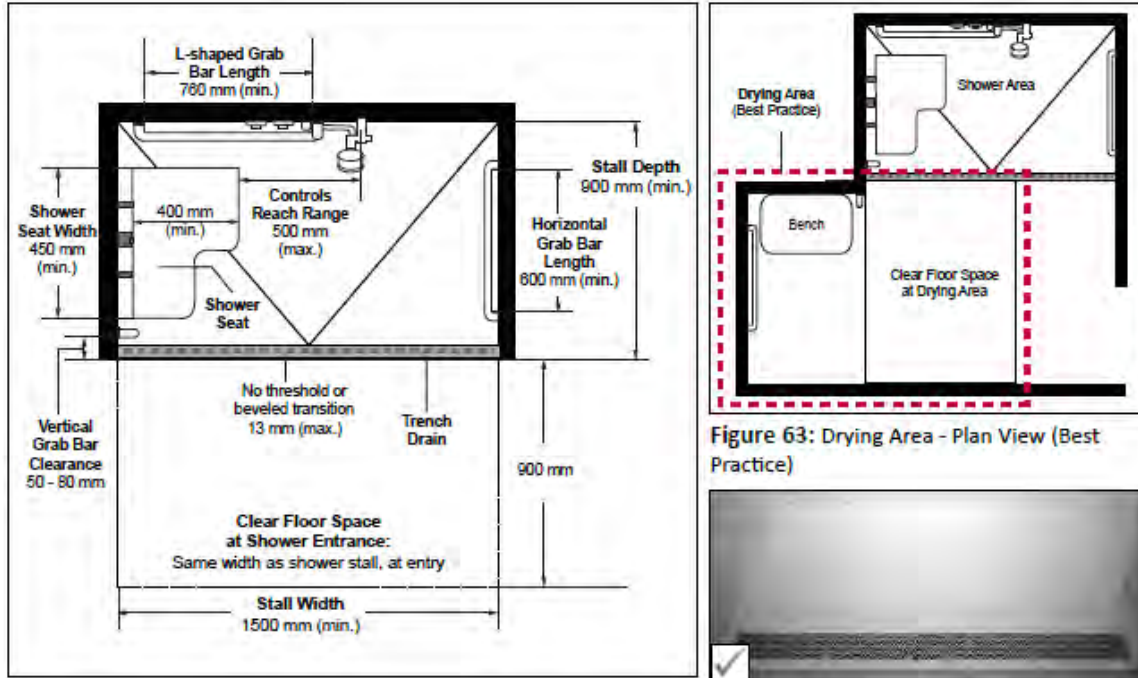

Figure 26: Example of shower design outlines

Controls and Accessories

General

1. Provide lever type or automatic controls that can be operated with a closed fist, mounted at 1,000 high above floor
2. Ensure all shower controls, including shower head, are located no more than 500 mm from the edge of the seat
3. Provide a pressure equalizing or thermostatic mixing valve to control water pressure and avoid scalding, mounted at 1,000 mm (maximum) high above floor
4. Provide fully recessed soap holders, mounted above grab bars between 900 mm and 1,200 mm, reachable from a seated position

Shower Head

1. Provide hand-held shower head with flexible hose 1,800 mm (minimum) length
2. Provide vertical support to mount shower head to allow operation as a fixed shower head
3. Ensure the vertical support allows shower head to be adjustable to 1,200 mm (maximum) height above floor and reachable from seated position
4. Ensure the vertical support placement does not obstruct the use of grab bars

Shower Seat

1. Provide a fixed shower seat or where a hinged seat is provided, ensure it is not spring-loaded
2. Mount shower seat on the side wall adjacent to the controls
3. Mount between 430 mm and 485 mm high above floor, with the front edge of the seat located within 500 mm of shower head and controls
4. Provide surface 450 mm wide by 400 mm deep (minimum) with rear edge 65 mm from wall
5. Mount securely, capable of holding a minimum load of 1.3 kilonewtons

Grab Bars

1. Ensure grasping surface is non-abrasive, slip-resistant and provide a high tonal contrast compared with mounting surface
2. Provide circular profile, with diameter between 35 mm and 40 mm
3. Ensure clear space of 50 mm (minimum) between mounting surface and grab bar, as well as between ends of grab bars and any adjacent wall
4. Mount securely to withstand a force of 1.3 kilonewtons applied in all directions

Vertical Grab Bars

1. Mount on the side wall adjacent to shower seat
2. Ensure length of 900 mm (minimum)
3. Mount with bottom edge between 600 mm and 650 mm high above floor to provide additional support when entering/exiting or when transferring to the seat
4. Provide a clearance between 50 mm and 80 mm from the adjacent clear floor space

L-Shaped Grab Bars

1. Mount on wall opposite to shower entrance between the shower head and shower controls
2. Ensure length of horizontal and vertical components is 760 mm (minimum)
3. Mount with horizontal component at 850 mm high above floor

Horizontal Grab Bars

1. Mount on the site wall opposite from shower seat
2. Ensure length of 600 mm (minimum)

3. Mount at 850 mm high above floor

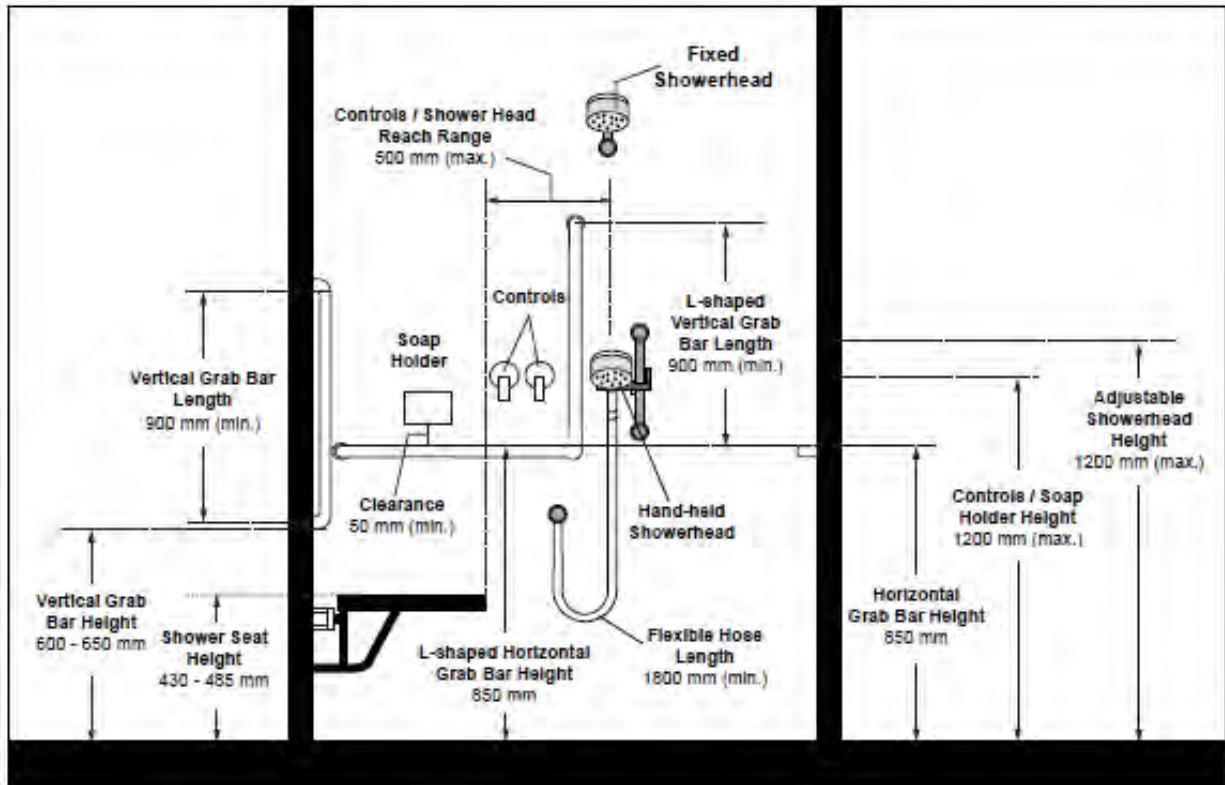

Figure 27: Examples of Grab Bars

COMMON ELEMENTS: INTERIOR AND EXTERIOR

Ground and Floor Surfaces

How the standard applies

This section applies to ground and floor surfaces throughout interior and exterior environments. The type of materials and finishes used for ground and floor surfaces are essential in determining accessibility.

STANDARDS

Surfaces

Ensure all ground and floor surfaces in interior and exterior environments:

1. Are firm, stable and slip-resistant
2. Have a matte finish to minimize glare
3. Are well-drained
4. Have joints between surfaces no wider than 6 mm (preferred) or 10 mm (maximum)
5. Where ground and floor surfaces have a change in level
 - no bevel is required (e.g., vertical change permitted), where the change in level is less than 6 mm
 - provide a beveled slope of 1:2 (maximum - the ratio rise to run), where the change in level is between 6 and 13 mm
 - provide a slope, ramp or curb ramp, where the change in level is greater than 13 mm
 - for exterior ground surfaces, refer to Exterior Paths of Travel for additional details

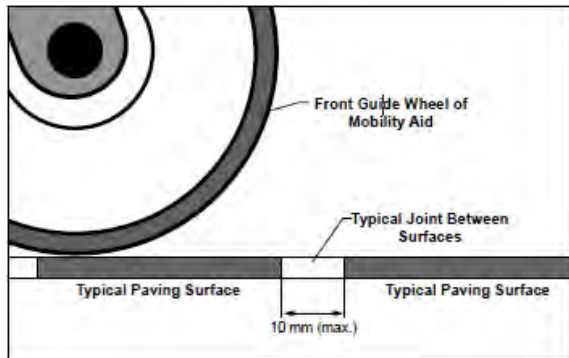

Figure 28: Example of between surfaces; a cross section view

Gratings and Surfaces

Openings can include sewer catch basin covers or drainage grates, utility covers and tree grates. Where there are any openings along the path of travel, or where gratings or other covers are required in both interior and exterior environments:

1. Ensure openings do not allow passage of an object with a diameter greater than 13 mm
2. Ensure that elongated openings are perpendicular to the pedestrian path of travel
3. Refer to OPS Standards

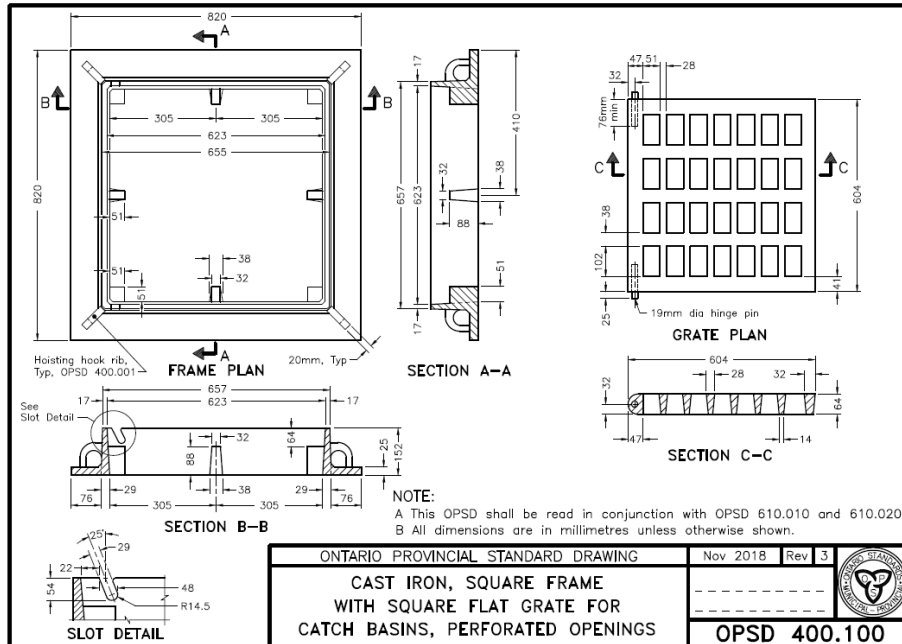

Figure 29: OPSD Grate Diagram

Ramps

How the standard applies

This section applies to ramps provided as part of an accessible route within exterior or interior environments. Additionally, refer to Ontario Building Code (OBC) and Integrated Accessibility Standards Regulation (IASR) for requirements for ramps.

STANDARDS

Design Features

1. Provide a clear width of 900 mm (minimum)
2. Ensure individual ramp sections are no longer than 9,000 mm
3. Provide landings:
 - o at top and bottom of ramp
 - o where there is any directional change
 - o between each ramp section where overall length of ramp exceeds 9,000 mm
4. Provide lighting in accordance Lighting requirements, as applicable
5. Provide handrails on both sides of the ramp
6. Provide a wall or guard on both sides of the ramp

Running Slope/Cross Slope

Refer to the OBC for slope references.

Edge Protection

Provide edge protection along ramps and landings:

1. With a curb at least 75 mm high (minimum) high, where no solid enclosure or solid guard is provided
2. With railings or other barriers that extend to within 50 mm of the finished ramp surface

Colour Contrasting Strips

1. provide a colour contrasted and slip-resistant strip at the beginning and end of ramp, and where landings meet a slope change
2. ensure strips are 50 ± 10 mm wide, extending along the width of the ramp

Landings

1. Ensure landings are level and have a cross slope that is not steeper than 1:50 (2%)
2. Provide clear space of 1,670 mm by 1,670 mm (minimum) at top and bottom landings and where there is an abrupt change in direction
3. Provide clear space of 1,670 mm (minimum) long and at least the same width as the ramp for an in-line landing
4. Where overall length of ramp exceeds 9,000 mm, provide intermediate landings
5. Where a door swings into ramp landing, ensure length of landing is extended:
 - o 600 mm beyond the latch side of the door opening, when the door swings towards the ramp landing
 - o 300 mm beyond the latch side of door opening, when door swings away from the ramp landing

Ramp Handrails and Guards

Handrails

1. Mount continuously on both sides of ramp, including landings, at consistent height between 865 mm and 965 mm, measured vertically from the surface of the ramp
2. Provide clear width of 900 mm (minimum) between handrails and/or any projections into the ramp surface

3. Provide intermediate handrails where exterior ramps are more than 2,200 mm wide, with a maximum of 900 mm between handrails
4. ensure high tonal contrast is provided between handrails and mounting surfaces
5. provide extensions with the following criteria
 - o extend horizontally 300 mm (minimum) at top and bottom landings
 - o design to return to the guard/rail or wall
 - o ensure handrails are terminated in a manner that will not obstruct pedestrian path of travel or create potential bumping hazards

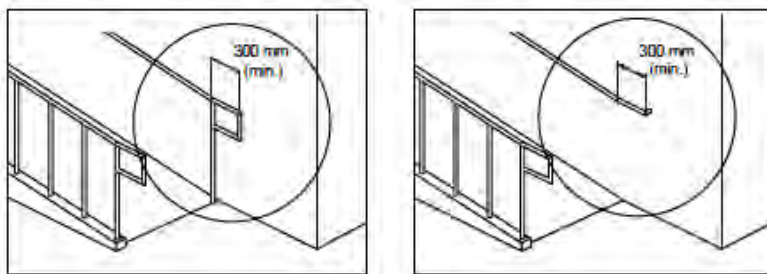

Figure 30: Example of handrail and guards

Guards

Where walls or guards are required:

1. Mount at 1,070 mm (minimum) high, measured vertically to the top of the guard from the ramp surface
2. Ensure that no member, attachment or opening located between 140 mm and 900 mm high above the ramp surface will facilitate climbing

For ramps under the jurisdiction of the IASR, the ramp must have a wall or guard on both sides. While *OBC Section 3.8.3.4* requires a wall or guard on both sides of the ramp, there are conditions in *OBC Section 9.8.8.1* that only require a guard if the difference in elevation is more than 600 mm or the adjacent surface within 1,200 mm has a slope steeper than 1:2.

Stairs

How the standard applies

This section applies to stair systems, where provided for exterior or interior environments.

Additionally, refer to Ontario Building Code (OBC) and Integrated Accessibility Standards Regulation (IASR) requirements for stairs.

STANDARDS

Design Features

1. Ensure surface is stable, firm, slip-resistant and non-glare
2. Provide lighting in accordance with Lighting requirements, as applicable

Treads and Risers

1. Riser height of 125 mm (minimum) to 180 mm (maximum)
2. Tread depth of 280 mm (minimum) to 355 mm (maximum)
3. Stairs must have closed risers
4. Ensure uniform riser height and tread depth throughout any stair system

Nosings

1. Ensure no abrupt undersides
2. Ensure leading edge is rounded or has a beveled profile, with a radius of curvature of not less than 6 mm and not more than 13 mm
3. Provide horizontal marking strips:
 - o 50 mm (+/- 10 mm) deep
 - o at the leading edge of the tread
 - o with a high tonal contrast compared to tread and riser finishes with slip-resistant surface
 - o extend the full width of the tread

Exception: Riser height and tread depth standards do not apply to interior exit stairwells. OBC does not differentiate between exterior and interior stairs.

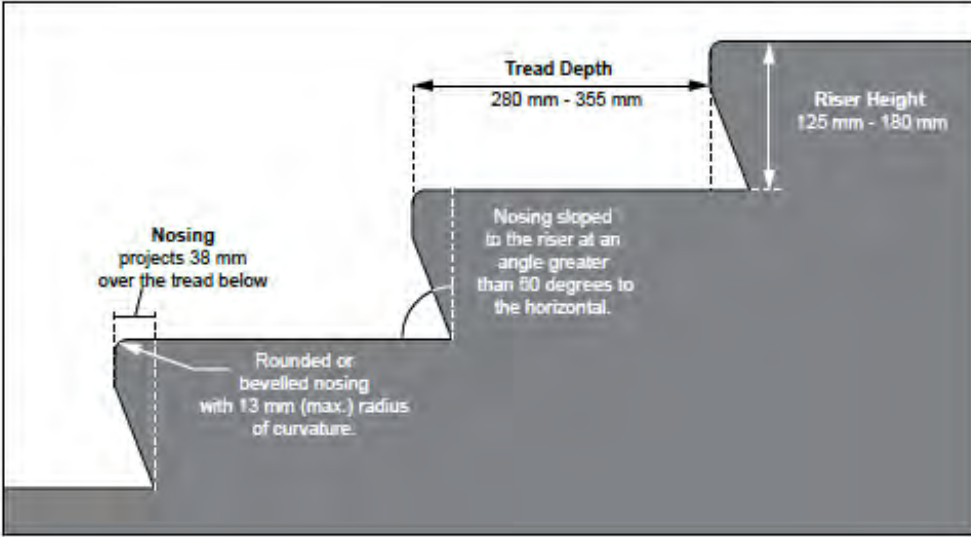

Figure 31: Nosing and stair tread depth requirements

Tactile Walking Surface Indicators (TWSIs) at Stairs

Provide tactile walking surface indicators (TWSIs):

1. At the top of all flights of stairs starting one tread depth back from the leading edge of the top step
2. At the top step, starting one tread depth back from the leading edge, at the following locations:
 - a. at each landing incorporating an entrance into a stair system
 - b. where the regular pattern of a stairway is broken
 - c. where the run of a landing which does not have a continuous handrail is greater than 2,100 m
3. With surface depth of 300 mm (minimum), extending the full width of the stair

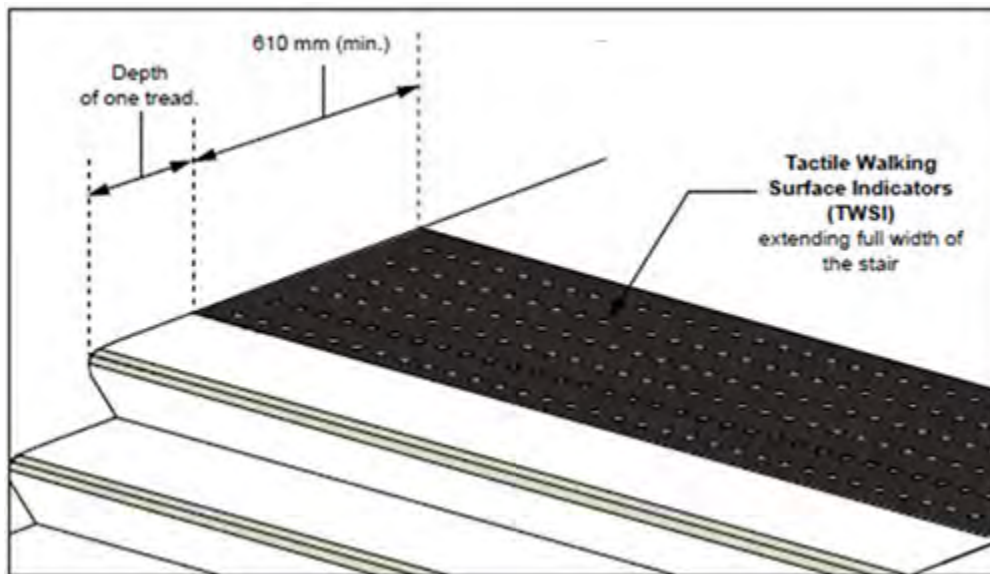

Figure 32: Tactile Walking Surface Indicator at top of stairs

Stair Handrails and Guards

Guards

Where there is a change in level 600 mm or more in floor level adjacent to stairs, provide guards as follows:

1. Mount at 1,070 mm (minimum) high, measured vertically to the top of the guard from the stair surface

2. Mount at 1,500 mm when stairs and landing are more than 1,000 mm above adjacent ground level
3. Provide edge protection
4. Ensure that no component, attachment or opening located between 140 mm and 900 mm high above the stair surface will facilitate climbing

Handrails

1. Mount on both sides of stairs, at a consistent height between 865 mm and 1,070 mm, measured from leading edge of stair tread
2. Ensure high tonal contrast is provided between handrails and mounting surfaces for improved visibility
3. Must be continuous around landing less than 2,100 mm in length from the top of stairs, except where the landing:
 - is intersected by an alternative accessible route; OR
 - has an entry door leading into it
4. Must be continuous on the inside edge of stairs
5. Where stairs are more than 2,200 mm wide, provide one or more intermediate handrails with a maximum of 1,650 mm between handrails
6. Provide extensions with the following criteria:
 - extend horizontally 300 mm (minimum) at top of flight of stairs, starting immediately above tread nosing
 - extend diagonally at the slope of the stair flight, for a horizontal distance equal to one tread depth beyond the bottom tread nosing, at bottom of flight of stairs then extend 300 mm parallel to the floor surface
 - design to return to the wall, guard or floor
 - ensure handrails are terminated in a manner that will not obstruct pedestrian travel or create hazards

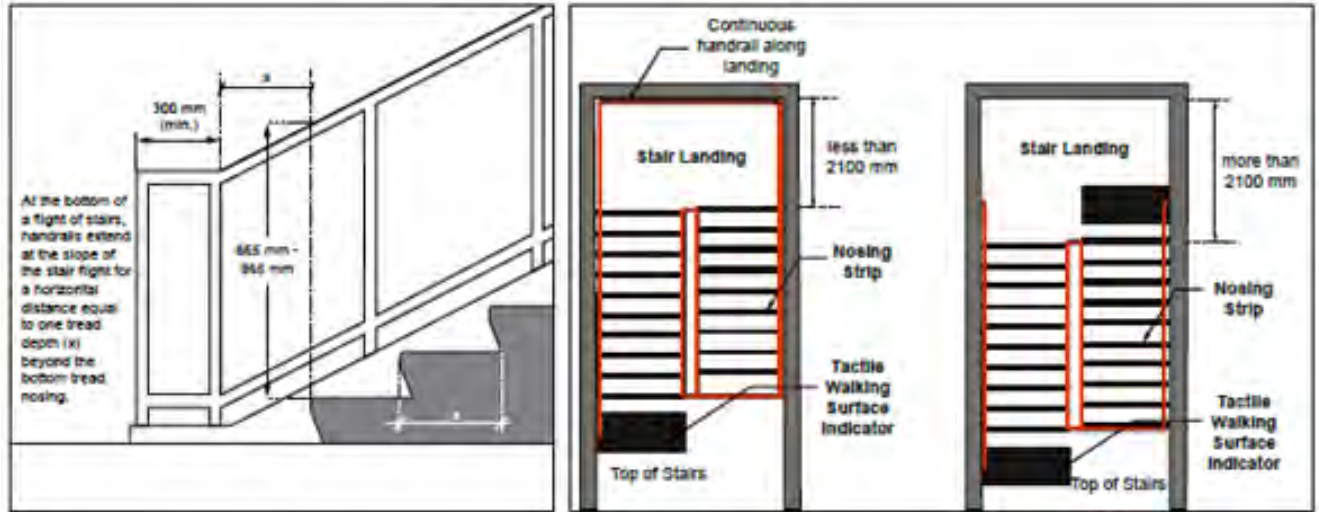

Figure 33: Stair shape

Handrails and Guards - General

How the standard applies

This section applies to guards and handrails in both interior and exterior environments. For more detailed information on guards and handrail standards for specific applications, refer to the relevant application section in this document (e.g. Ramps, Stairs, etc.).

STANDARDS

Guards

1. Ensure they comply with the OBC or IASR requirements, as applicable
2. Mount at 1,070 mm (minimum) high, measured vertically to the top of the guard from the ground/floor surface
3. 1,500 mm when at the stairs
4. Design to prevent the passage of a sphere with a diameter greater than 100 mm
5. Ensure no member, attachment or opening located between 140 mm and 900 mm high above the level protected by the guard will facilitate climbing

Handrails

1. Ensure handrails are continuous with grasping surface, uninterrupted by mounting brackets, newel posts or any other construction elements
2. Provide rounded edges, free of abrasive elements

3. Provide outside diameter between 30 and 43 mm for circular cross-section, which is preferred
4. Where non-circular cross sections are provided, ensure perimeter dimension of 100 mm (minimum) and 125 mm (maximum), with cross section dimension of 45 mm (maximum)
5. Provide clearance of 50 mm (minimum) between grasping surface and any adjacent surface
6. Be designed and constructed such that handrails and their supports withstand:
 - the loading values obtained from the non-concurrent application of a concentrated load not less than 0.9 kilonewton applied at any point and in any direction
 - a uniform load not less than 0.7 kN/m, applied in any direction
7. Lower handrails are required
 - height for lowered hand rail railing is 600 mm – 700 mm

Rest Areas

How the standard applies

This section applies to rest areas provided along accessible paths of travel within a facility or throughout exterior environments. Benches and seating are provided at rest areas and waiting areas for people who may have difficulty with standing or walking for extended periods or limited stamina.

STANDARDS

Consultation Requirements

1. When constructing new or redeveloping existing exterior paths of travel that will be maintained, consultation on the design and placement of rest areas must occur with:
 - the Haldimand County Accessibility Advisory Committee.

Design and Placement

To determine the provision and placement of rest areas, consider the input received through the consultation process and other factors such as available space, property requirements, location of transit stops, and volume of pedestrian traffic.

1. Rest areas shall be spaced no more than 30 m apart in an urban setting and no more than 110 m in a trail to maximize the usability of the paths of travel for people with reduced stamina.
2. Where rest areas are provided:
 - ensure ground and floor surfaces are firm, stable and slip-resistant
 - consider providing contrast through ground finish, texture and/or tone to distinguish the rest area from the accessible path of travel
 - provide an additional clear floor space beside the bench of 1,700 mm wide by 1,350 mm long (minimum)
 - where seating is provided, ensure seating offers both armrests and backrests
3. For accessible benches and seating provided in both interior and exterior environments:
 - ensure seat height is between 450 and 500 mm above finished floor/ground
 - ensure seat depth is between 330 and 510 mm
 - bench length will be a minimum of 1,820 mm
 - provide back support, extending 320 mm (minimum) above the seat surface, or affix the seat to a wall
 - provide at least 1 arm rest at a height between 220 and 300 mm from the seat for additional support
 - ensure bench is stable at all times
 - ensure seating surfaces provide high tonal contrast with surroundings to enhance visibility

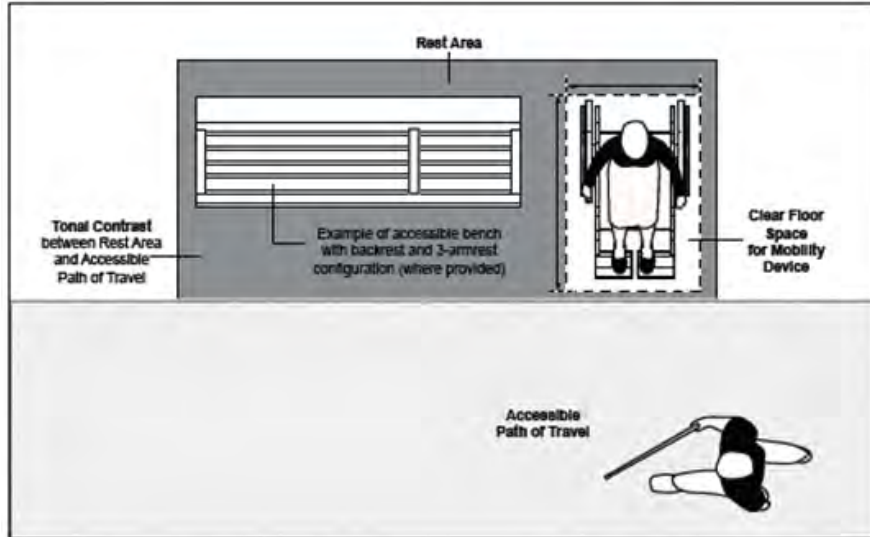

Figure 34: Example of bench with pad for mobility aides

Tactile Walking Surface Indicators (TWSIs)

How the standard applies

Tactile walking surface indicators (TWSIs) refers to a standardized surface, detectable underfoot or by a long white cane, to assist people with low vision or blindness by alerting or guiding them.

Typical locations where TWSIs are required include:

- at curb ramps and depressed curbs
- where walking surfaces between pedestrian and vehicular areas are not separated by curbs
- at stairs

Both cast in place (e.g., embedded within concrete) and surface-applied TWSI systems are available for new construction and retrofits depending on the mounting surface and application. Surface applied systems require beveled edges to prevent potential tripping hazards. Refer to the OPS.

STANDARDS

Design Features

1. Provide tactile walking surface indicators (TWSIs) with:

- a. raised tactile profile
- b. truncated domes (e.g., circular and flat-topped domes)
- c. slip-resistant and non-glare surfaces
- d. a high tonal contrast between the TWSI and the adjacent surfaces
- e. edges beveled or level with surrounding surface (e.g., height of 3 mm or less)

Seating, Tables, and Work Surfaces

How the standard applies

This section applies to site and facility furniture, provided in both exterior and interior environments which typically includes, but is not limited to seating (e.g., benches), tables and work surfaces.

Some common locations, where site and facility furniture can be found include:

- rest areas and accessible routes
- dining facilities
- outdoor public use eating areas
- waiting areas
- lobbies
- office environments

STANDARDS

Benches and Seats

The provision of benches and seats is typically recommended for people who may have difficulty with standing or walking for extended periods, limited stamina, or for users of mobility aids.

For accessible benches and seating provided in both interior and exterior environments:

1. Ensure seat height is between 450 and 500 mm above finished floor/ground
2. Ensure seat depth is between 330 and 510 mm
3. Bench length will be a minimum of 1,820 mm
4. Provide back support, extending 320 mm (minimum) above the seat surface, or affix the seat to a wall

5. Provide at least 1 arm rest at a height between 220 and 300 mm from the seat for additional support
6. Ensure bench is stable at all times
7. Ensure seating surfaces provide high tonal contrast with surroundings to enhance visibility

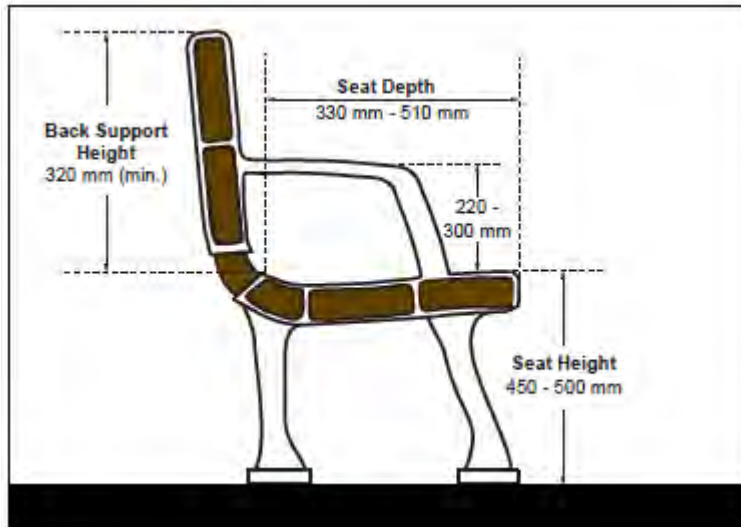

Figure 35: Chair dimension requirements

Tables and Work Surfaces

1. Ensure top surface is between 730 mm and 865 mm high
2. Provide clear knee space of:
 - o 760 mm wide (minimum)
 - o 480 mm (minimum) deep by 685 mm high (minimum)
3. Where toe clearance is required based on table design, ensure toe space is 350 mm (minimum) high by 230 mm (minimum) deep
4. Ensure top surface and edges provide a high contrast with adjacent surroundings to enhance visibility; and
5. Ensure clear floor space provided at table and work surfaces for users of mobility aids is:
 - o 760 mm wide by 1,370 mm deep (minimum), of which 480 mm (maximum) may be under the table for forward approach
 - o 1,525 mm wide by 915 mm deep (minimum) for a side approach

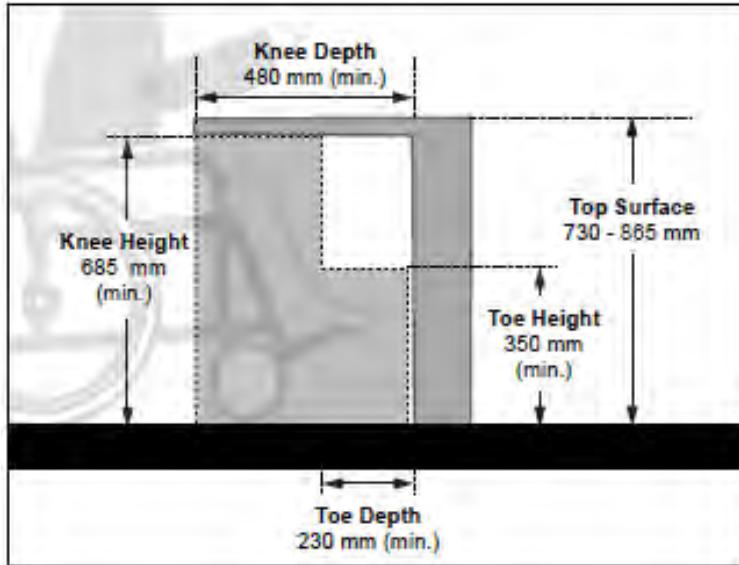

Figure 36: Table and workplace leg clearances from side

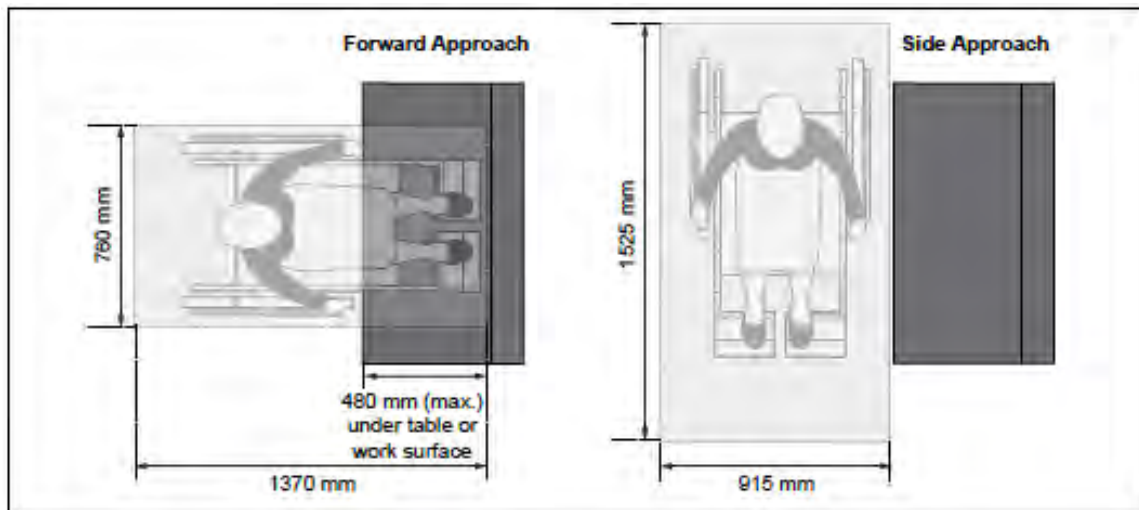

Figure 37: Table and workplace leg clearances from above

CONTROLS AND OPERATIONG MECHANISMS

General Controls and Operations

How the standard applies

This section applies to typical interior and exterior controls and operating mechanisms provided for public and staff use, throughout accessible routes and spaces.

Examples of typical controls and operating mechanisms related to interior and exterior environments include, but are not limited to:

- entrance call buttons or intercoms
- light switches
- wall outlets/duplexes
- fire or other alarm system controls (e.g., washroom emergency alarms)
- thermostats
- door hardware
- plumbing fixture hardware (e.g., faucets and water closet flush controls).

Controls related to product and dispensing machines, such as food and beverage vending equipment, payment stations for parking and ticketing devices, touch screen devices for information and self-service kiosks and other activation devices are also required to be accessible.

STANDARDS

Design Features

Ensure accessible controls and operating mechanisms address the following:

1. Are usable with closed fist and operable with one hand
2. Do not require tight grasping, pinching of the fingers, or twisting of the wrist
3. Can be used with force of 22 newtons (maximum)
4. Where push-button type controls are provided, button surface has a minimum diameter of 13 mm and is not recessed
5. Ensure controls are visible from a distance, based on use of high tonal contrast between operable parts and adjacent mounting surface
6. Mount controls and operating mechanisms

- no lower than 400 mm high for all controls
- at 1200 mm high for thermostat and manual fire alarm pull
- between 900 and 1100 mm high for all other controls and operating mechanisms
- so that they extend not more than 200 mm and not less than 900 mm high above the floor for vertical extended power door operators

7. Locate in prominent and obvious locations, for easy identification

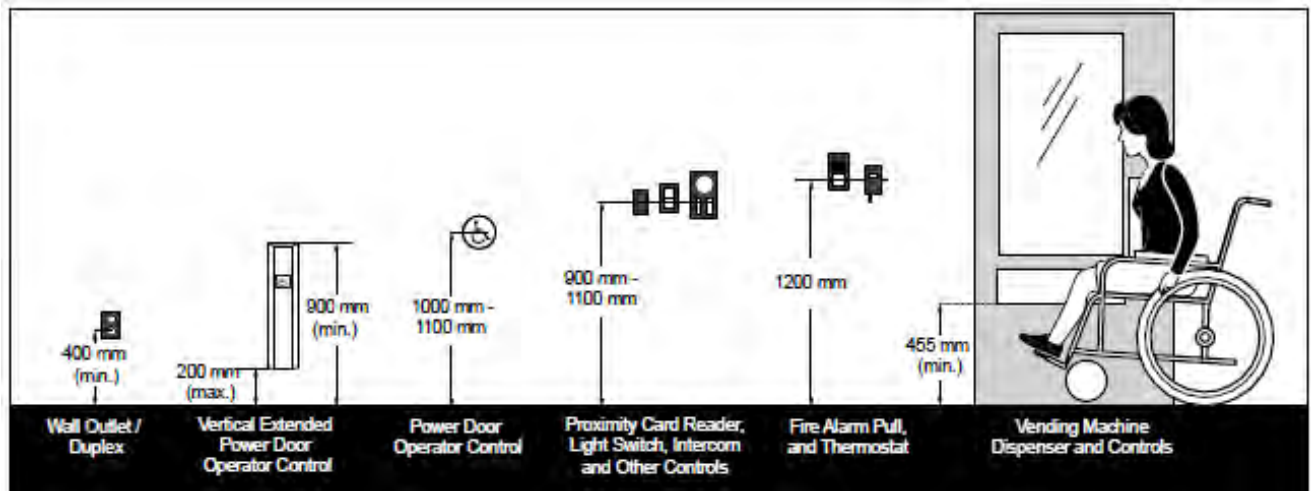

Figure 38: Examples of various control mounting heights

Floor Space

Floor Space Requirements

1. provide a clear floor space at controls and operating mechanisms of:
 - 915 mm wide by 1,370 mm depth for a forward approach
 - 1,525 mm wide by 915 mm depth for a side approach

Reach Requirements

For both a forward and side approach, ensure the following mounting heights of controls and operating mechanisms for suitable reach are provided:

2. Where there is no obstruction in front of controls and operating mechanisms:
 - no lower than 400 mm
 - at 1200 mm for thermostat and fire alarm pull controls
 - no higher than 1100 mm for other controls and operating mechanisms

3. Where there is an obstruction of no more than 860 mm high:
 - o no higher than 1,100 mm, which allows for a touch reach over a 600 mm deep obstruction or a grasp reach over a 500 mm deep obstruction

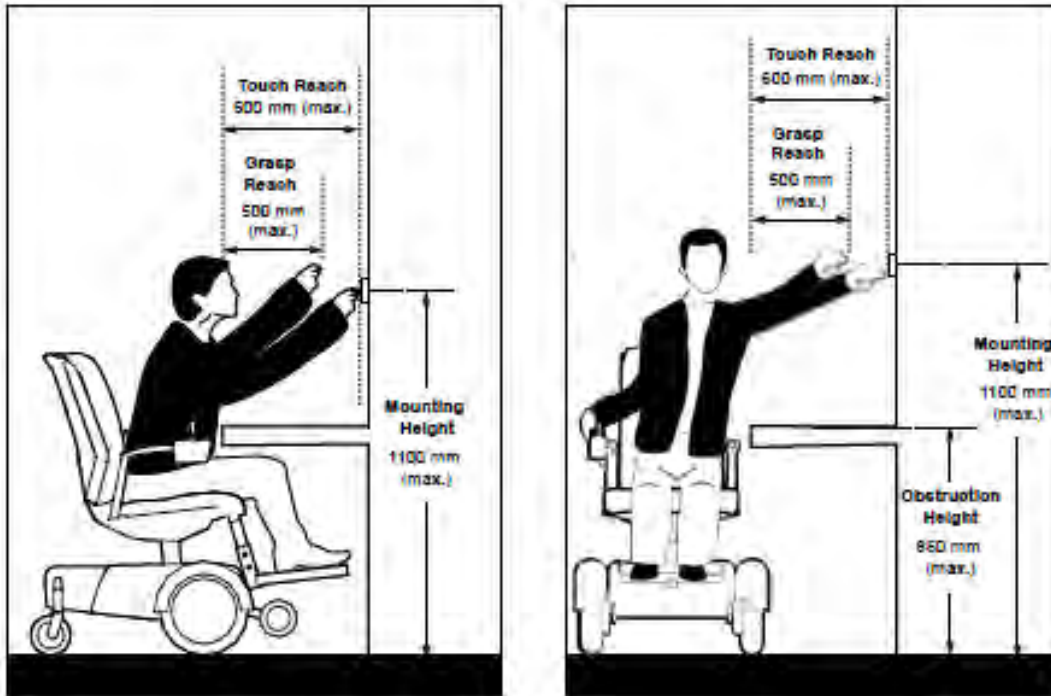

Figure 39: Reaching standards

Assistive Listening Devices

How the standard applies

This section applies to assistive listening systems, required in assembly areas, including but not limited to classrooms, auditoria, meeting rooms and theatres:

- with an area of 100 square metres or occupancy of seventy-five (75) or more fixed seats
- where audible communication is integral to the use of the space
- where audio amplification devices are used.

Induction loops, infrared systems and FM radio frequency systems are considered acceptable types of assistive listening systems for persons with hearing loss.

Wireless sound transmission systems, such as FM, infrared or magnetic induction loop, improve sound reception for the hard of hearing by providing amplification which can be adjusted by each user while blocking out unwanted background noise. These systems transmit a signal that

is picked by special receivers available for use by people with a hearing disability, whether or not they use a hearing aid.

The transmitter can be jacked into an existing P.A. system amplifier or used independently with microphones. The induction loop system requires users to sit in the area circumscribed by the loop; though installation of the loop is relatively simple, the installer should be knowledgeable about these systems if proper functioning is to be achieved.

FM or infrared systems can be designed to broadcast signals which cover the entire room and, thus do not restrict seating to any one area. Although portable systems (FM in particular) are available, these are best suited to small audiences. Generally, the systems installed in church halls, auditoria, theatres and similar places of assembly are not easily portable, as they are installed in a fixed location by a sound technician and form an integral part of the P.A. system of the room or building.

STANDARDS

Assistive Listening Design Features

For assistive listening systems, whether permanent or portable, ensure:

1. System usability encompasses the entire floor area
2. System provides personal amplification control
3. System performs with or without the use of hearing aids
4. Signage is provided with the International Symbol for Hearing Loss pictogram to identify the availability of the assistive listening system and it is also marked with a 'T', where T-coil usage is available

Assistive Listening Systems

Permanent Assistive Listening Systems

Where permanent systems are provided:

1. The minimum number of required receivers is equal to 4% of the total number of seats, but never less than two
2. The minimum number of required receivers to be hearing aid compatible is 25% of the total number of receivers that are provided, but never less than one

Portable Assistive Listening Systems

1. Provide at least one portable assistive listening system, with a minimum of two receivers included for facilities with assembly spaces on multiple floor levels (e.g., this provides enhanced flexibility for the systems to be available and used at different locations)
2. Ensure portable assistive listening systems include hearing aid compatibility

Acoustics

How the standard applies

This section applies to achieving a suitable acoustical environment, which can provide an additional wayfinding cue for persons with vision and/or hearing loss:

STANDARDS

Design Features

1. Integrate the use of sound-reflective or sound absorbent materials to differentiate essential sounds from general background sounds
2. Select floor, wall and ceiling finishes to ensure that occasional noise is not unintentionally amplified (e.g., avoid hard floor surfaces such as marble and terrazzo)
3. Design ceiling shapes so that echoes do not occur
4. Minimize all background noise (e.g., fans, mechanical systems, air conditioners and diffusers) in meeting rooms and assembly areas where spoken word is key to understanding proceedings
5. Integrate and include adequate sound insulation in room and space design
6. Install a permanent inductive loop or similar assistive listening system for high use buildings and areas, especially where the surrounding environment may be noisy

Security Systems

How the standard applies

This section applies to typical security systems (e.g., proximity card readers, alarm systems), which are used to provide and limit access to areas of a facility.

STANDARDS

Design Features

Where users control independent entry or exiting to secured areas of facilities:

1. Locate controls between 900 mm to 1,100 mm from the floor
2. Mount controls at least 600 mm clear of the arc of any door swing
3. Where electronic keypads or push-button systems are provided, ensure buttons are raised from surface, mounted on surface with high tonal contrast and have raised numerals or letters to assist users with vision loss
4. Ensure both audible and visual indicators are provided to alert users when access has been granted or denied
5. Where proximity card readers (e.g., swipe cards) are used at doors equipped with power door operators, ensure activation of both systems is synchronized
6. Provide high tonal contrast on system controls, compared to mounting surface

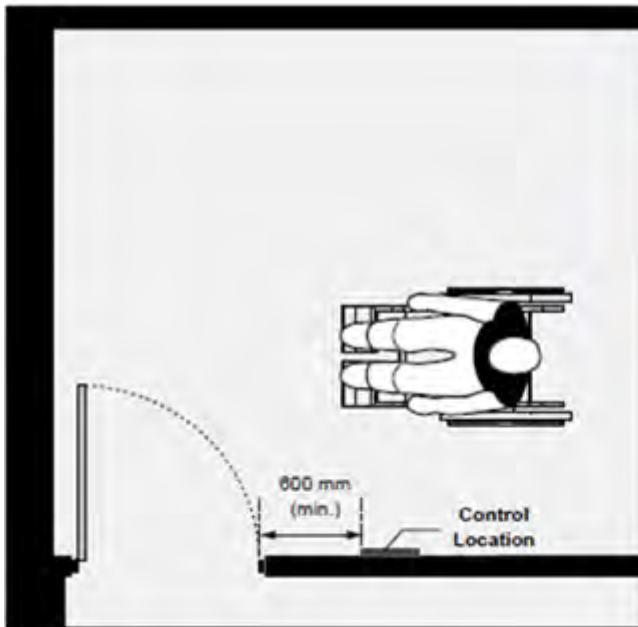

Figure 40: Example of door card reader



Example of proximity card reader system that is large in size with high tonal contrast compared to mounting surface for enhanced visibility.



Example of proximity card reader system with visual indicator.

Fire and Life Safety Systems

How the standard applies

This section applies to fire and life safety systems, addressing the needs of people with varying disabilities, in emergency situations. Key components of typical fire and life safety systems include, but are not limited to:

- evacuation plans
- alarm signals (both audible and visual)
- 'Areas of Refuge'
- emergency exits

STANDARDS

Fire Safety and Evacuation Plans

1. Provide a fire and life safety evacuation plan that addresses the needs of users with varying disabilities:
 - for facilities with floors above or below grade, develop a fire safety and evacuation plan, indicating in detail the preferred evacuation strategies for persons with disabilities (e.g., "Buddy System" where staff can help co-workers with disabilities evacuate)
 - ensure the base of evacuation plans are posted no higher than 1,200 mm from the floor
 - ensure evacuation plans incorporate a font size of 14 point (minimum)
 - ensure evacuation plans are available in alternate formats
 - provide signage to identify evacuation plans
2. Mount safety controls and operating mechanisms:
 - between 900 mm and 1,100 mm from floor for emergency and life safety controls and operating mechanisms such as fire extinguishers, first aid kits and defibrillators
 - at 1200 mm high from floor for manual fire alarm pull

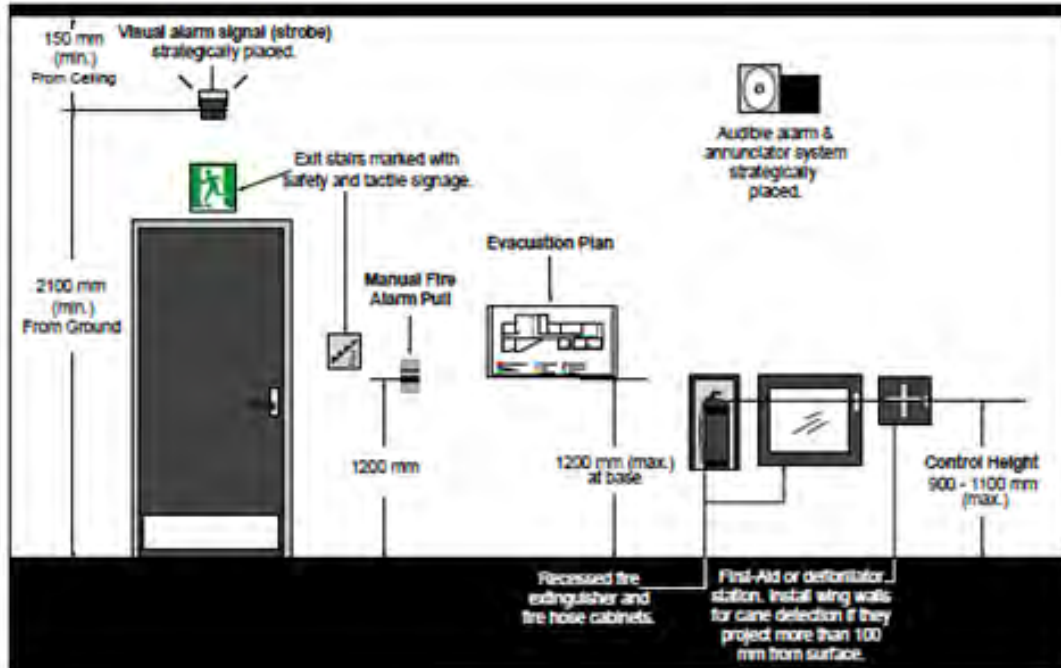

Figure 41: Fire evacuation layout

Visual Alarm Systems

Where visual alarm signals are provided for users with hearing loss:

1. Integrate visual alarm signals with required audible fire alarm system, including during retrofit projects where achievable
2. Mount appliance at 2,100 mm (minimum) above the floor level within the space or 150 mm below the ceiling, whichever is lower
3. Where visual alarm signals are provided in any common space, public corridor, hallway, lobby or room, ensure they are placed no more than 15 m apart, on the horizontal plane
4. Install visual alarm signals so that the signal from at least one device is visible throughout the floor area or portion of it in which they are installed
5. Ensure light and flashing features are based on the following criteria:
 - use a xenon strobe type or equivalent for light or lamp fixture
 - ensure clear or nominal white colour (e.g., unfiltered or clear filtered white light)
 - provide maximum pulse duration of 0.2 seconds, with a maximum duty cycle of 40 percent
 - ensure the intensity of the visual alarm signal raises the overall light level sharply, but not so intense as to be unsafe for direct viewing

- ensure a flash intensity of 75 candela (minimum) with a flash rate between 1 hertz (minimum) and 3 hertz (maximum)
- synchronize visual alarms that are located in the same proximity to flash at the same time



Example of combined visual and audible alarm signals. Public facilities should have both visual and audible fire alarm systems strategically located.

Figure 42: Fire alarms

Areas of Refuge

Where an Area of Refuge is included as a component of a facility's fire safety and evacuation plan for persons with disabilities:

1. Locate on an accessible route, which is served by an exit or fire fighter's elevator
2. Locate clear of any adjacent door swing and away from pedestrian exit route(s)
3. Ensure the area is easy to identify and designated with signage (e.g., large print, tactile features stating Area of Refuge and marked with the International Symbol of Accessibility)
4. Ensure a clear floor space of at least 1,675 mm by 1,675 mm is provided to accommodate users of mobility aids
5. Provide protective enclosure for a minimum of one-hour
6. Provide a two-way, accessible communication system supported by the facility's backup generator and linked to the designated fire control centre/panel
7. Ensure communication system is marked with signage and includes both audible and visual notification devices to indicate "help is on the way"

8. Provide separate emergency lighting and ventilation systems supported by a backup generator

Lighting

How the standard applies

This section addresses lighting requirements for both interior and exterior environments.

STANDARDS

Lighting Level Requirements

For lighting level requirements for interior and exterior environments, designers must refer to the appropriate reference document for detailed requirements. Reference documents include:

1. Ontario Building Code
2. Illuminating Engineering Society of North America's *The Lighting Handbook*

Lighting Design Best Practices

Exterior Lighting

1. Ensure lighting sources are located at or beside all ramps, steps and stairs, to illuminate and identify surfaces, treads, risers, nosing's and handrails
2. Ensure all lighting over pedestrian routes is evenly distributed and provides a reasonable colour spectrum while minimizing any shadows casted
3. Provide supplementary lighting to highlight all wayfinding signage, as required
4. Ensure lighting fixtures or posts do not encroach on accessible routes/paths of travel
5. Ensure low-level lighting standards are mounted high enough to clear normal snow accumulation heights
6. Ensure overhead light fixtures are mounted with clear headroom of 2,100 mm (minimum)

Interior Lighting

1. Use natural light wherever possible to illuminate entrances, corridors and key workspaces; however, avoid designs that results in direct glare reflected from flooring or work surfaces
2. Integrate sources of both artificial and natural lighting to provide comfortable, evenly distributed light at working surfaces and throughout circulation routes

3. Ensure lighting design allows an illumination quality that is as close to a full spectrum as possible to aid in identifying edges and colour contrasts which are used as wayfinding cues (this ensures the warm end of the spectrum provides appropriate colour definition)
4. Ensure any leading edge of stairs, steps, ramps or escalators are evenly lit; and
5. Ensure sources of light (natural or artificial) are not positioned at the ends of corridors or behind people at reception areas or counters

Signage and Wayfinding

How the standard applies

This section applies to signage and wayfinding strategies, where provided in exterior and interior environments. Recognizing that signage programs and wayfinding strategies are customized based on facility types and use of space, the information and criteria in this section is provided as a starting point.

There are different types of signage for various purposes:

- **Regulatory signs** - includes prohibition signs denoting an order forbidding an action, and mandatory signs which denote an order requiring an action
- **Warning signs** - includes caution and danger signs denoting a potential hazard and a definite hazard, respectively
- **Identification signs** - includes rooms, titles, names or numbers that are provided for general orientation or specific information, such as washrooms, routes of egress, stairwells, doorways or offices

STANDARDS

Signage

Design Features

1. Ensure signage surfaces have matte, eggshell or non-glare finish
2. Ensure signage is of uniform design
3. Provide colour contrast between signage and mounting surfaces
4. Where used to give the same type of information within the same facility, ensure signage is consistently shaped, coloured and positioned

5. Where facilities or elements, including but not limited to washrooms, elevators, telephones, information kiosks, routes, areas of refuge, and parking facilities are accessible, provide signage with the International Symbol of Accessibility to designate as accessible
6. Provide lighting in accordance with Lighting Requirements, as applicable, at signs

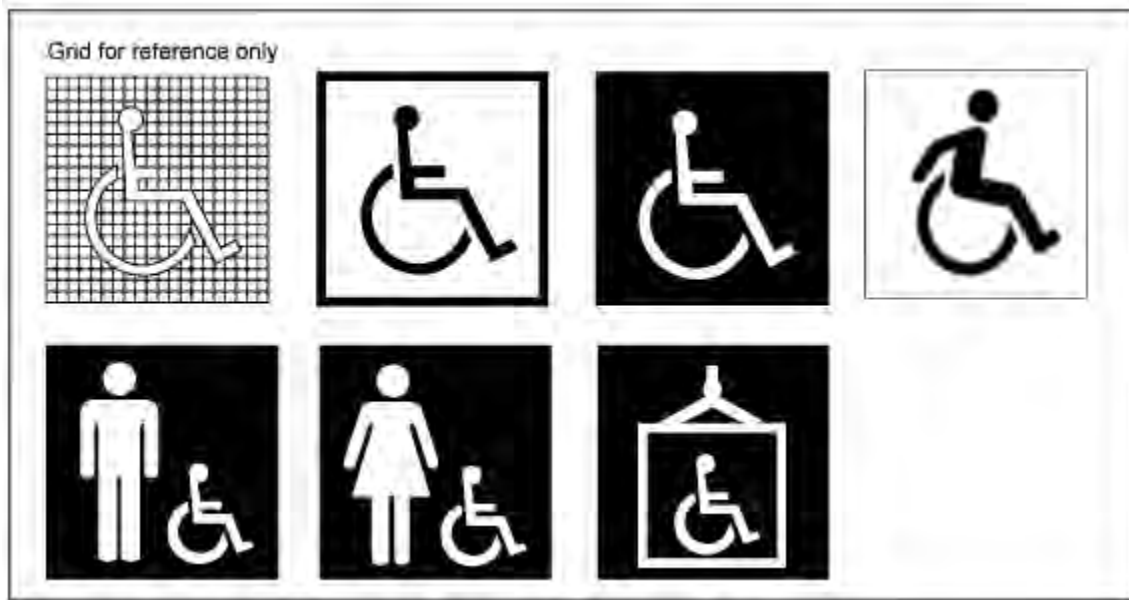

Figure 43: Examples of pictogram signs for disability

Character Features and Sizes

1. Ensure text characters (e.g., letter or number) are sans serif font type and have Arabic numerals (e.g. 1, 2, 3, etc.)
2. Where text is provided, ensure it is bilingual
3. Provide width to height ratio between 3:5 and 1:1
4. Provide stroke width to height ratio between 1:5 and 1:10
5. Ensure characters are not italic, oblique, script, highly decorative or of other unusual forms
6. Provide high tonal contrast between text characters and background surface
7. Ensure the minimum character height is provided as per viewing distance as identified on page 73
8. Use an uppercase "X" for character measurement

Table 6: Character requirements for signs

Minimum Character Height (mm)	Maximum Viewing Distance (mm)
200	6,000
150	4,600
100	2,500
75	2,300
50	1,500
25	750

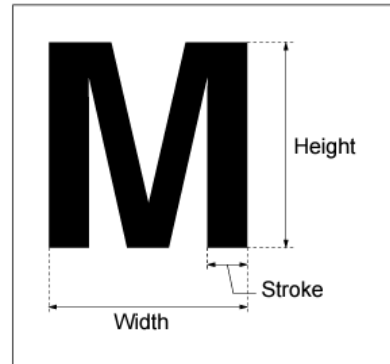

Pictograms and Symbols

Pictograms and symbols are used to complement text information and identify important facility features, elements or services, including information desks, public washrooms, and elevators.

Where pictograms are used:

1. Ensure pictogram has a field height of 150 mm (minimum)
2. Provide text descriptors and braille directly below the pictogram field and not in the pictogram field
3. Provide high tonal contrast between pictogram the field
4. Use the International Symbol of Accessibility to identify accessible facility features, spaces, elements and amenities
5. Use recognized and standardized symbols for accessibility features or other key building elements (e.g., washrooms, telephones and elevators) to facilitate wayfinding for all users

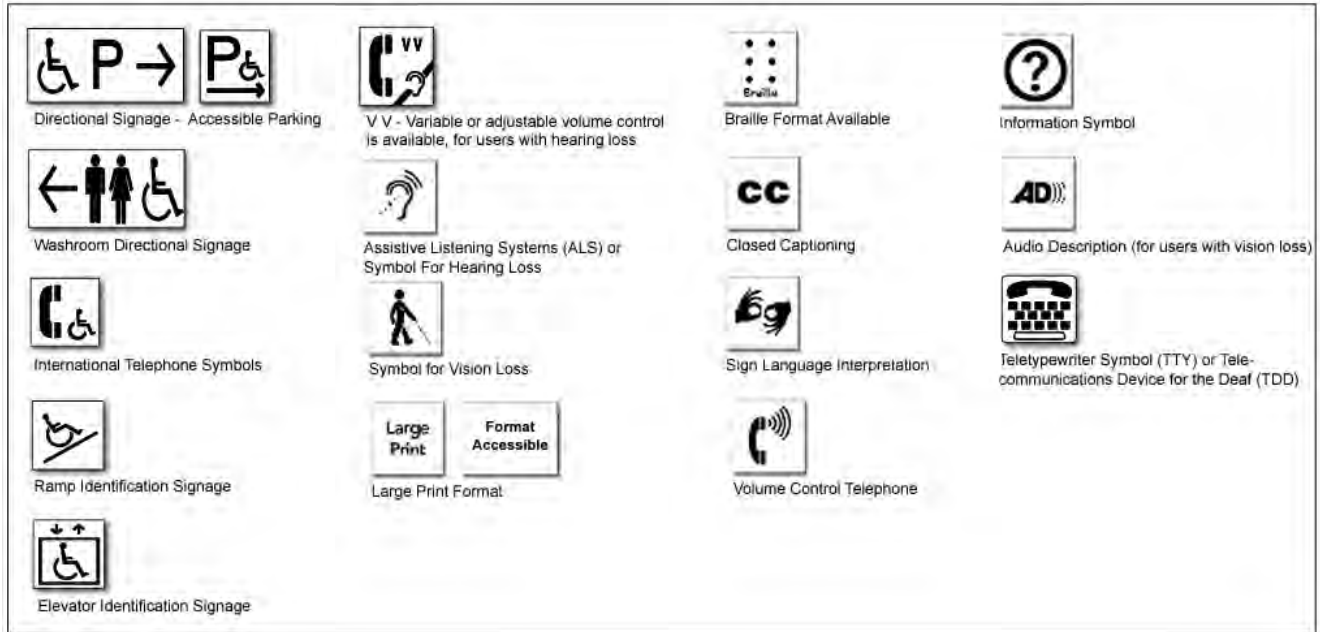

Figure 44: Pictogram examples

Wayfinding Principles

1. Ensure consistent design, strategic placement and ideal mounting heights at key decision-making points along accessible routes for all signage
2. Provide high tonal contrast between signage and mounting surfaces for full visibility
3. Ensure there is no information overload or cluttering of signage to avoid confusion
4. Avoid placing suspended signs against a light source to ensure full visibility (e.g., at the end of corridors which have windows, glass doors or window walls)



FACILITIES

Assembly Areas

How the standard applies

This section applies to assembly areas in both interior and exterior environments. The following common assembly areas require accessible seating spaces:

- Civic spaces (e.g. Council Chambers, public meeting or hearing rooms, auditoriums, multi-purpose rooms at community or recreation centres, stages/podiums)
- Entertainment/Cultural spaces (e.g. theatres, museums)
- Sporting spaces (e.g. arenas, stadiums, gyms, grandstand stages)

STANDARDS

Design and Layout

1. Ensure lighting level is evenly distributed throughout all accessible routes and accessible seating spaces
2. Ensure a consistent accessible path of travel of 1.8 m (minimum) throughout space for circulation
3. Provide accessible seating options for users of mobility aids
4. Provide assistive listening systems, designed for the type of venue and audience
5. Ensure all audio-visual equipment, features, controls and related technology are usable by all participants and staff, where provided, including the provision of instructions and guidance in alternative formats

Accessible and Adaptable Seating

Where fixed seating is available in assembly occupancies:

1. provide accessible seating spaces for users of mobility aids and adaptable seating based on total number of fixed seats, as identified below.

Table 7: Accessible seating requirements

Total Number of Fixed Seats	Minimum Number of Accessible Seats	Minimum Number of Adaptable Seating
Up to 20	2	1
21 to 40	2	2

41 to 60	2	3
61 to 80	2	4
81 to 100	3	5
More than 100	3% of seating capacity	The greater of 5 seats or 5% of the aisle seating capacity

Accessible Seating Spaces

1. Install directional signage in prominent locations to identify location of accessible seating spaces
2. Locate spaces adjoining an accessible path of travel, without infringing on egress from any row of seating
3. Provide at least one fixed companion seat adjacent to accessible seating spaces and within the same row, ensuring shoulder alignment for users sitting beside each other
4. When entering from side, ensure clear floor space at accessible seating spaces is 1,525 mm wide by 915 mm deep (minimum)
5. When entering from rear or front, ensure clear floor space at accessible seating space is at least 915 mm wide by 1,400 mm deep (minimum)
6. Ensure at least two accessible seating spaces are provided side by side
7. Where accessible seating spaces are situated as part of the designated seating plan, provide a choice of viewing location and ensure there is a clear view of the event taking place
8. Where accessible seating spaces are provided on an elevated platform, ensure the lines of sight are:
 - o comparable to those for all viewing positions
 - o not reduced or obstructed by standing members of the audience
 - o free of any obstructions (e.g., any barriers, handrails, guardrails or columns)
9. Ensure accessible seating spaces are positioned so that they do not obstruct sight lines of other users either sitting or standing

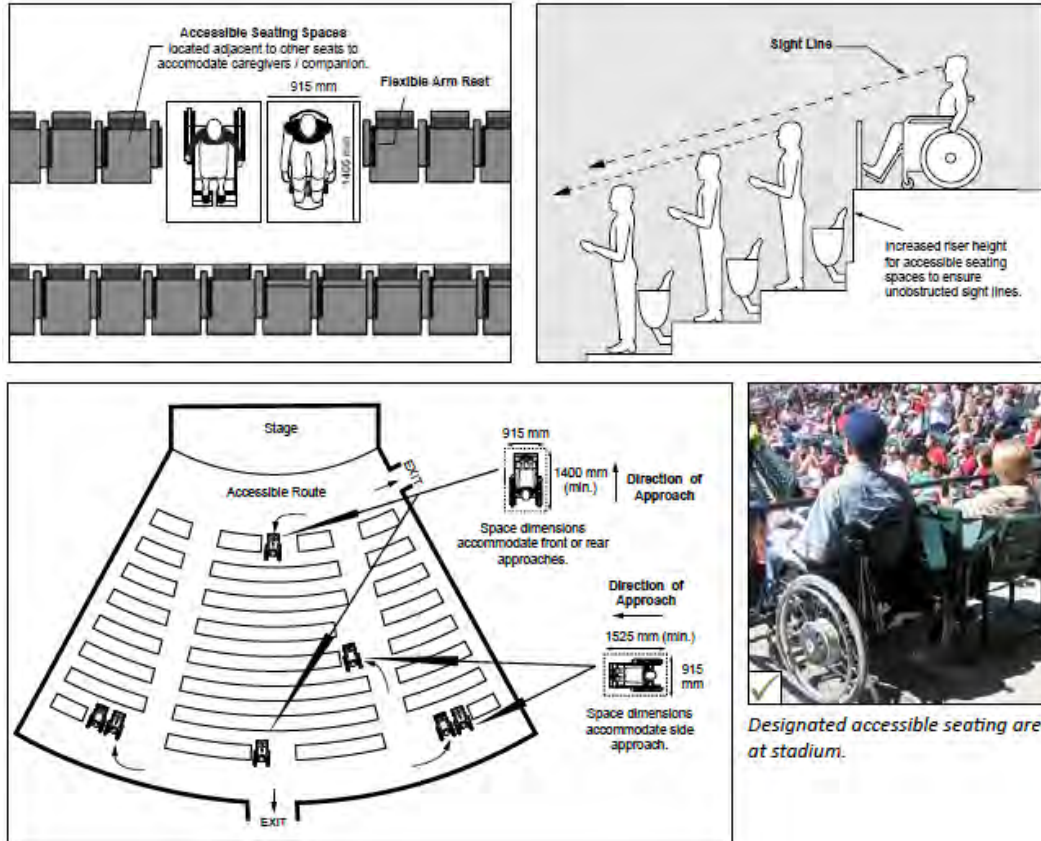

Figure 45: Examples of accessible seating plans

Adaptable Seating

1. Locate adjacent to an accessible route without infringing on egress from any row of seating or any aisle requirements
2. Equip with a movable or removable armrest on the side of the seat adjoining the accessible route
3. Locate, as part of the designated seating plan, and provide a choice of viewing location with a clear view of the event taking place

Storage for Mobility Aids

1. Ensure at least 1 storage space where not more than 200 fixed seats are provided and a minimum of 2 storage spaces, where more than 200 fixed seats are provided
2. Provide a clear floor space of 915 mm wide by 1,370 mm deep (minimum) for each space
3. Locate storage space on the same level and in proximity to the accessible seating spaces and seats designated as adaptable seating

Meeting and Multi-Purpose Rooms

How the standard applies

This section applies to highly-used and large meeting and multi-purpose rooms used by public and staff within a facility.

STANDARDS

Design and Layout

1. Locate on an accessible path of travel
2. Identify meeting/multi-purpose room(s) location with appropriate signage
3. Ensure a consistent accessible path of travel of 1,100 mm clear width (minimum) is provided throughout space for circulation
4. Provide a turning diameter of at least 1,675 mm within the room
5. Provide accessible tables and work surfaces with suitable knee clearances and seating, as identified in related sections
6. Provide assistive listening systems, identified with signage and International Symbol for Hearing Loss
7. Where a servery or millwork is provided, ensure clear floor space is:
 - 915 mm wide by 1,370 mm deep (minimum) for forward approach
 - 1,525 mm wide by 915 mm deep (minimum) for side approach
8. Ensure all audio-visual equipment, features, controls and related technology are usable by all participants and staff, where applicable, including the provision of instructions and guidance in alternative formats
9. Provide lighting in accordance with Lighting requirements, as applicable, at work surfaces

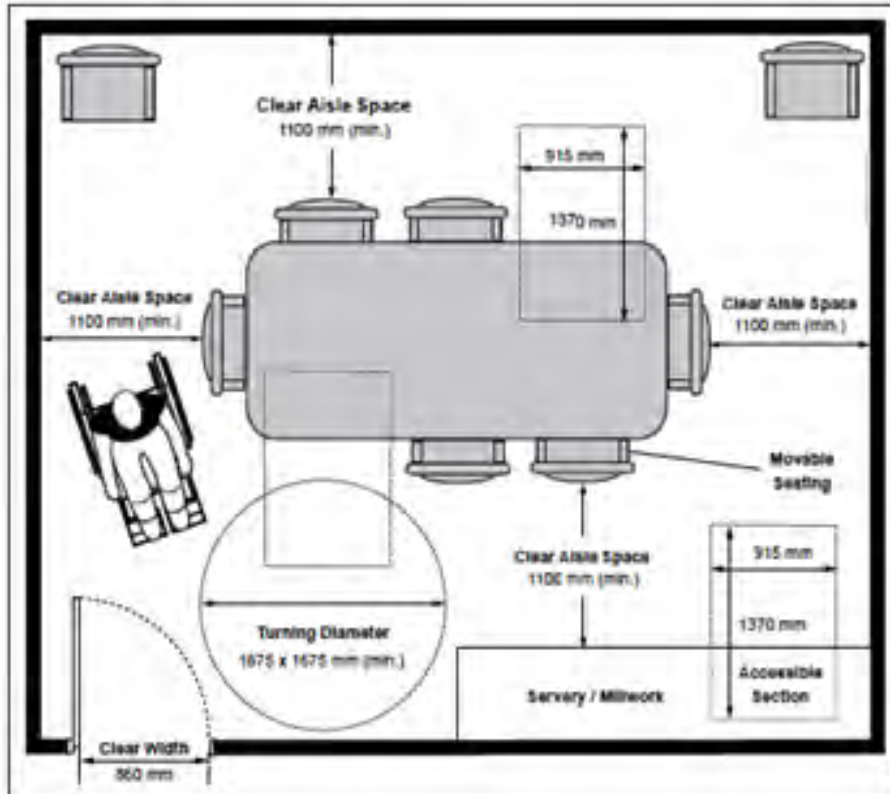

Figure 46: Layout of accessible meeting room

Cultural and Art Facilities

How the standard applies

This section applies to cultural and art facilities, which include, but are not limited to, art galleries, theatres, museums and heritage sites.

Recognizing there are unique circumstances and challenges related to improving accessibility of heritage sites and facilities, additional considerations beyond architectural and physical design are often required. These can include staff training and awareness, additional use of technology and implementation of facility-specific management policies and practices.

STANDARDS

Design and Layout

1. Ensure accessible path of travel 1,100 mm (minimum) wide throughout circulation space
2. Where exhibits or displays follow a specific order, ensure circulation route is intuitive
3. Provide an accessible floor plan or map to facilitate in wayfinding

4. Provide assistive listening systems in large assembly, meeting or performance areas
5. Where exhibits and displays are provided:
 - mount top surface of display cases at 915 mm high (maximum) from floor;
 - provide clear floor space of 915 mm wide by 1370 mm deep (minimum) for forward approach and 1525 mm wide by 915 mm deep (minimum) for side approach in front of exhibits;
 - provide a high tonal contrast between the items exhibited and adjacent background;
 - eliminate or minimize glare that may be reflected from display surfaces or covers;
 - provide lighting in accordance with lighting requirements, as applicable, at display labels for reading; and
 - where interactive displays are provided, ensure controls and operating mechanisms are mounted at 1100 mm high (maximum) from floor.

Kitchen and Kitchenettes

How the standard applies

This section applies to common-use kitchens and kitchenettes, for public and staff, typically available as amenities in public facilities, such as office environments and community centres, where multi-purpose activity rooms are provided.

STANDARDS

Design and Layout

1. Ensure floor surface is slip-resistant and has a non-glare finish
2. Ensure the following minimum clear floor space is provided directly in front of kitchen amenities and appliances, and to the one side where drawers or door open:
 - 915 mm wide by 1,370 mm deep for forward approach
 - 1,525 mm wide by 915 mm deep for side approach
3. Ensure all controls and operating mechanisms are mounted no higher than 1100 mm from floor
4. Provide lighting in accordance with lighting requirements, as applicable, with task lighting option also available (e.g., under counter)

Libraries

How the standard applies

This section applies to libraries or a designated room in a facility that is used for the same purpose.

It is recognized that libraries have unique space requirements in order to accommodate book stacks and reference materials at both high and low shelving heights. Shelving heights in collection areas with book stacks is unrestricted where County Staff are available to assist users when requested.

Ensure staff availability is coordinated as part of a formal Accessible Customer Service policy, practice or procedure that is in place for all Library facilities

STANDARDS

Design and Layout

1. Provide a consistent accessible path of travel of at least 1,100 mm wide throughout spaces for circulation
2. Provide turning diameter of 1,675 mm in order to allow users of mobility aids to make a 180 degree turn
3. Where provided, ensure security gates have a clear width of 915 mm
4. Provide at least one accessible service counter at circulation, information or self-service checkout areas
5. Where online catalogues or other workstations are provided, ensure at least 25% are accessible
6. Provide lighting in accordance with Lighting Requirements, as applicable
7. Ensure acoustic quality is free of unnecessary background noise
8. Provide informational and directional signage where any services or amenities for users with disabilities are available on different floor levels (e.g., Information or Customer Service Desks)
9. Ensure library staff are provided with disability awareness/sensitivity training

Book Drop Slots

1. Locate on an accessible path of travel

2. Provide clear floor space in front of drop slot:
 - o 915 mm wide by 1,370 mm deep for a forward approach
 - o 1,525 mm wide by 915 mm deep for a side approach
3. Ensure a high tonal contrast between drop slot and mounting surface
4. Locate slot between 900 and 1,100 mm above the floor
5. Ensure slot controls are usable with closed fist and operable with one hand

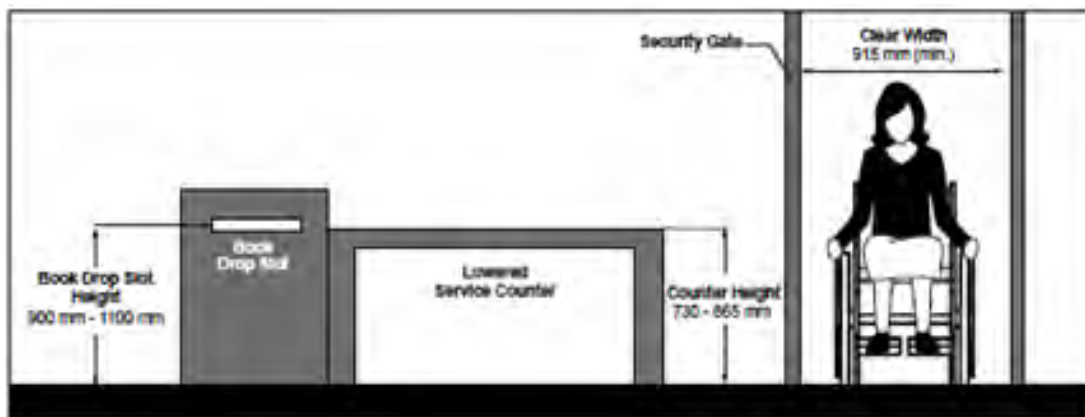

Figure 47: Accessible library returns counter

Book Stacks or Carousels

1. Ensure accessible path of travel of at least 1,100 mm between aisles
2. Ensure library policy is in place to provide assistance for users to access items that are too high or too low
3. Ensure large print collection and heavier materials are placed on lower shelves for easy access

Reading Lounges and Study Areas

- a. Provide a variety of flexible seating options
- b. Ensure a high tonal contrast is provided between furniture and their surroundings
- c. Ensure all study tables, study carrels and work surfaces provide suitable knee and toe clearances with at least 10% of each surface type fully accessible
- d. Incorporate an electric outlet

Recreational and Community Facilities

How the standard applies

This section applies to recreational and community facilities, whether indoor or outdoor, used by spectators, participants, volunteers, coaching staff and facility employees.

Recreational and community facilities include, but are not limited to:

- courts (e.g., basketball, volleyball, tennis)
- fields (e.g., baseball, soccer, football)
- arenas (e.g., ice pad, skating rinks)
- aquatic facilities (e.g., swimming pools, spas, wading pools, splash pads, saunas)
- gymnasiums
- exercise and fitness facilities

Criteria in this section requires detailed review and application based on the type of facility, level of use and number of features or elements provided (e.g., total number of change rooms).

STANDARDS

Design and Layout

The design and layout of recreational and community facilities, typically consists of the following elements.

Change Rooms

1. Provide at least one accessible change room, with at least one accessible change cubicle to accommodate parents with children, companions or care givers of the opposite sex

Viewing Area

1. Provide level accessible seating spaces to accommodate users of mobility aids
2. Integrate assistive listening systems or visual equipment, depending on the type of venue

Arenas

For access to ice pads and skating rinks in arenas:

1. Locate on an accessible path of travel
2. Provide access panels to ice surface with clear width of at least 860 mm
3. Provide level or beveled access to ice pads or skating rinks

Exercise and Fitness Facilities

1. Ensure accessibility features are provided, if available, for at least one of each type of equipment or machine
2. Provide a clear floor space of 915 mm by 1,370 mm (minimum) for a front approach or 915 mm by 1,525 mm for a side approach on one side of exercise equipment to allow transfer

Aquatics Facilities

1. Ensure pool deck surfaces are firm, stable, slip-resistant and have a matte finish
2. Ensure deck surface has running or cross-slope gradient no steeper than 1:50 (2%) for drainage of water
3. Provide recessed drainage tiles with openings no greater than 13 mm wide
4. Provide an accessible path of travel around the perimeter of pool deck at 1,100 mm (minimum) wide
5. Provide tactile walking surface indicators (TWSI) 610 mm wide to clearly delineate the perimeter of the pool deck and locate where any area contiguous to the pool deck may be confused with the deck
6. Provide high tonal contrast on pool lane markers, related tie-off devices, starter blocks and any other permanent or temporary equipment (e.g., life-guard chairs, diving boards or platforms, safety equipment)

Entry and Exit Point

1. Provide at least one accessible entry and exit point:
 - o ensure entry and exit point is located away from any designated swimming lanes

Sloped Entry or Ramp

1. Ensure running slope is no more than 1:12 (8.33%)
2. Provide handrails, mounted between 865 mm and 965 mm high from surface, extending at top landing only
3. Ensure the clear width between handrails is 1,100 mm (minimum)

4. Provide top and bottom landing of at least 1,670 mm by 1,670 mm
5. Ensure water depth at the bottom of the ramp is at least 600 mm and not greater than 900 mm
6. Provide a hard-surfaced area capable of accommodating a movable barrier separating the area from the deck, and is 750 mm (minimum) wide that is contiguous to the entire length of the part of the submerged ramp that pierces any part of the deck
7. Ensure the finishes in the submerged portions of the ramps and curbs are different in colour or shade from each other and from that of the pool walls and bottom

Change Rooms

How the standard applies

This section applies to change rooms, which may also be referred to as dressing/locker rooms or fitting areas, used by the public or staff. These spaces share common elements and design features. Typically, change rooms are provided in arenas, pools, fitness centres and related recreation/community centres.

STANDARDS

Provision and Location

For Universal Change Rooms or Stalls that are intended for private use in addition to other public or staff change rooms that may be available:

1. Provide at least one universal change room or stall for each type of other regular change room facility that is provided (e.g., Male, Female or Universal Change Room)
2. Ensure universal change rooms or stalls are located along an accessible route

Design and Layout

1. Where doors are provided at the change room entrance, provide a clear width of 860 mm (minimum) and equip with power door operators
2. Provide a consistent accessible path of travel 1,100 mm (minimum) wide throughout spaces for circulation in the change room
3. Ensure a clear turning diameter of 1,500 mm (minimum) is provided inside change room circulation area to allow users of mobility aids to make an 1,800 turn
4. Ensure the floor surface is slip-resistant and allows suitable drainage

5. Where washroom facilities are provided as part of a change room, provide accessibility design requirements, in accordance with washrooms requirements, as applicable
6. Where shower facilities are provided as part of a change room, provide accessibility design requirements, in accordance showers requirements, as applicable
7. Provide lighting in accordance with lighting requirements, as applicable
8. Provide an emergency call system with the following features:
 - a. includes an emergency bilingual sign containing the words “IN THE EVENT OF AN EMERGENCY PUSH EMERGENCY BUTTON AND AUDIBLE AND VISUAL SIGNAL WILL ACTIVATE” in letters at least 25 mm high with a 5 mm stroke, that is posted above the emergency button
 - b. consists of visual and audible signal devices both inside and outside of the change room that are activated by a control device inside the change room
 - c. where facilities have the capacity and where staff is available, ensure the call system is linked to a display panel at a reception/information counter or to a centrally monitored station (e.g., security desk)

Change Room Amenities

Change room amenities typically include, but are not limited to, benches, lockers, showers and washrooms.

Permanent Benches

Where permanent benches are provided:

1. Provide seat height of 480 to 520 mm above finished floor to allow users of mobility aids to transfer
2. Ensure seat depth between 510 mm to 610 mm, with back support, unless seat surface is permanently positioned against a wall
3. Provide high tonal contrast finishes to assist with distinguishing bench surfaces from surroundings



Consistent accessible path of travel, space for circulation and lockers mounted at different heights.

Figure 48: Path of travel in locker room

Lockers

Where lockers are provided inside change rooms:

1. Ensure at least 10% of the total number of lockers but never less than one is designated as accessible; identify accessible lockers clearly with signage (e.g., International Symbol of Accessibility)
2. Provide a clear floor space in front of accessible lockers of:
 - 915 mm wide at 1370 mm deep (minimum) to allow for a forward approach
 - 1525 mm wide by 915 mm deep (minimum) to allow a side approach
3. Mount bottom shelf between 400 mm and 1200 mm high from the floor
4. Ensure locking mechanism is mounted between 900 mm and 1,100 mm high above floor
5. Ensure identification/number signage for all lockers:
 - mount no higher than 1,500 mm (centre)
 - provide lettering or number print size between 13 mm and 19 mm high, with either raised or recessed lettering
 - provide a high tonal contrast with the background

Universal Change Rooms or Stalls

1. Identify clearly with signage (e.g., International Symbol of Accessibility)
2. Provide a clear turning diameter of 1,675 mm (minimum) inside of the change room or stall
3. Ensure floor surface is firm, level and slip-resistant

4. Provide an entrance door or stall door with:
 - a clear width of 860 mm (minimum), when door is in an open position
 - a locking mechanism that can be locked from the inside and released from the outside, in case of emergency
 - spring hinges or gravity hinges in the case of a stall door, so that door closes automatically, where the door swings outwards
 - a power door operator, where an entrance door is required for a private universal change room
5. Provide a change bench 1,830 mm long by 760 mm wide, mounted with top surface between 480 and 520 mm high
6. Provide grab bars with specifications identified in grab bar section:
 - install one L-shaped grab bar at the end of the bench, with the vertical component, 150 mm (minimum) from front edge of seat and clearance of 150 mm (minimum) above the bench seat
 - install one horizontal grab bar, 1,200 mm (minimum) long, mounted 750 to 850 mm high and centered on the long side of the bench
7. Provide motion sensor for automatic illumination of the interior, and lighting in accordance with lighting requirements, as applicable
8. Include a full-length mirror

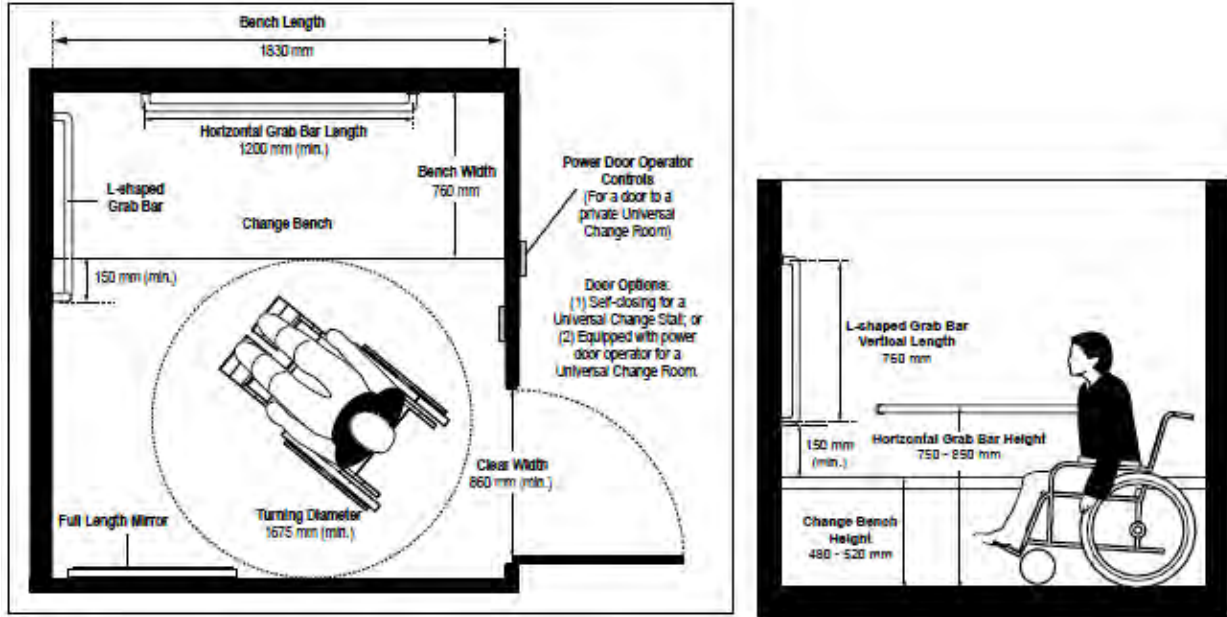

Figure 49: Example of Universal Change Room Design

Service Counters

How the standard applies

This section applies to service counters used by both the public and staff, whether the services are obtained in the buildings or outdoors. Service counters may include, but are not limited to:

- reception desks
- check-out counters
- teller counters
- information desks or kiosks
- food service counters

STANDARDS

Provision

1. Where a single queuing line serves a single or multiple counters, ensure each service counter is accessible
2. Where there are multiple queuing lines and service counters, ensure at least 1 service counter is accessible for each type of service provided

Design and Layout

1. Locate on an accessible path of travel
2. Where there are multiple queuing lines and service counters, provide signage (e.g., International Symbol of Accessibility) to identify the accessible service counter(s)
3. Provide clear floor space in front of service counters for users of mobility aids:
 - 760 mm wide by 1370 mm deep to allow forward approach
 - 1525 mm wide by 915 mm deep to allow side approach
4. Ensure service counter surface provides a high tonal contrast compared with adjacent surfaces to identify counter when approaching
5. Provide lighting in accordance with lighting requirements, as applicable
6. Provide a lowered counter usable from seated position:
 - with top surface mounted between 730 mm and 865 mm high above floor
 - ensure a clear knee space under the counter of at least 480 mm deep by 760 mm wide by 685 mm high
 - ensure maximum forward reach of 635 mm deep across top

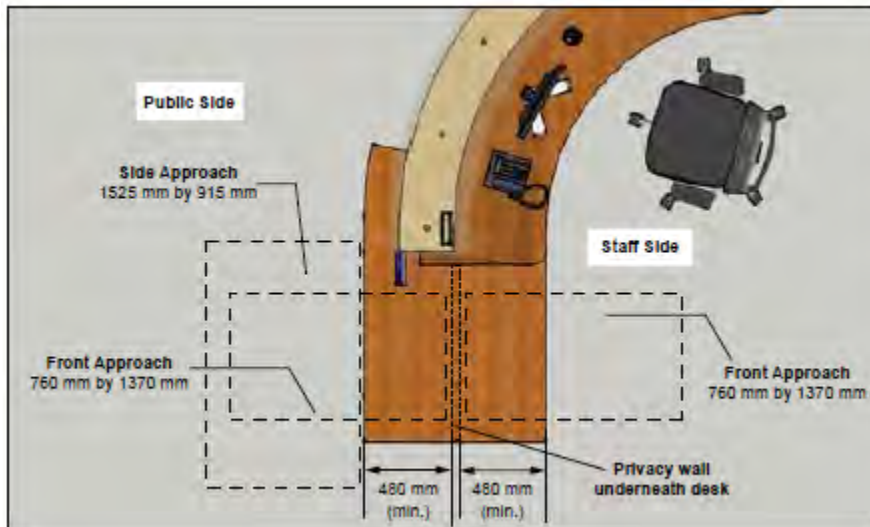

Figure 50: Accessible counter examples

Outdoor Public Use Eating Areas

How the standard applies

This section applies to newly constructed and redeveloped outdoor public use eating areas at public facilities, which typically provide tables (e.g., picnic tables) intended for public use as a place to consume food.

STANDARDS

Design and Layout

1. Ensure a minimum of twenty percent (10%) of tables and no fewer than 1 in outdoor public use eating area are accessible
2. Ensure accessible tables provide suitable knee and toe clearances
3. Provide a clear space of 2,000 mm (minimum) on all sides of the table
4. Locate on an accessible path of travel or trail
5. Ensure ground surface leading to and under tables is firm, stable and no steeper than 1:50 (2%)
6. Provide directional signage at strategic locations to identify the location(s) of accessible tables and or public use eating areas
7. Where barbecues are provided in outdoor public use eating areas, ensure they are placed away from the accessible path of travel and on a surface with high tonal and textural contrast with the adjacent surfaces
8. Where washrooms are provided, ensure accessible features (e.g., at least one universal toilet room, per cluster of regular washrooms)

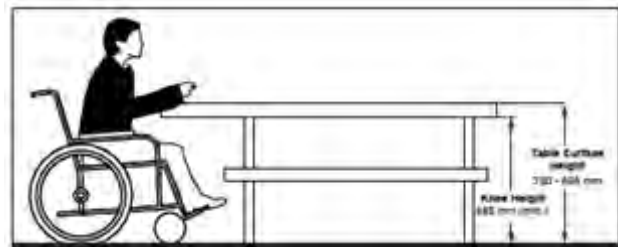
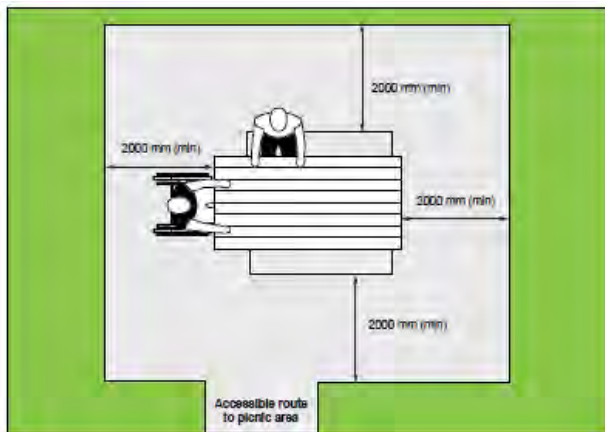

Figure 51: Accessible picnic area and bench

Recreational Trails, Beach Access Routes and Boardwalks

How the standard applies

This section applies to:

- Newly constructed and redeveloped recreational trails that the County intends to maintain

- Newly constructed and redeveloped beach access routes that the County intends to maintain, including permanent and temporary routes that are established through the use of manufactured goods, which can be removed for the winter months
- Boardwalks that are part of newly constructed or redeveloped recreational trails and beach access routes that the County intends to maintain

Exception(s): the standards do not apply to trails solely intended for cross-country skiing, mountain biking or the use of motorized snow vehicles or off-road vehicles, wilderness trails, backcountry trails and portage routes;

Recreational Trails

Consultation Requirements

Before constructing new or redeveloping existing recreational trails, the County will consult with the Accessibility Advisory Committee, the public, and persons with disabilities on:

1. The slope of the trail
2. The need for, and location of, ramps on the trail
3. The need for, location and design of,
 - rest areas;
 - passing areas;
 - viewing areas;
 - amenities on the trail; and
 - any other pertinent feature.

Trails are not considered the same as exterior routes, paths and walkways. Trails do not include pathways such as public sidewalks or pathways between buildings.

Designated Trailheads

1. Ensure designated trailheads with information signage are integrated as part of the trail design, at key entrance and exit points along the trail, intermediate areas on lengthy trails or decision points (e.g., changes in elevation or where there is option to go in multiple directions) where required. Typically, a case-by-case review and analysis is required, based on trail type, location and other conditions.

A trailhead is a designated point of access that may contain a parking area, information kiosks, information signage, rest areas, washrooms, water fountains or other user amenities, which are typically reached by vehicular or pedestrian access.



Figure 52: Trailhead design

Trail Clear Width

1. Provide clear width of 1.5 m minimum
2. Ensure headroom clearance is 21 m (minimum) above the trail
3. Ensure no obstructions or projections along trail

Trail Surfaces

1. Ensure surface is firm and stable
2. Surface will be made of compacted stone dust, asphalt pavement, concrete or similar
3. Ensure that openings must not allow passage of an object that has a diameter of more than 13 mm and that any elongated openings are oriented approximately perpendicular to the direction of travel
4. Ensure resistance to damage by normal weather conditions, with ability to sustain typical wear and tear between planned maintenance cycles
5. Ensure type of surface used and expected conditions that may change over time are identified in information signage provided at trailhead

Edge Protection

Where recreational trails are constructed adjacent to water or a drop-off, provide edge protection with the following requirements:

1. Constitute of an elevated barrier that runs along the edge the recreational trail to prevent users from slipping over the edge
2. Have the top of the edge protection at 50 mm (minimum) high above the trail surface
3. Be designed so as not to impede the drainage of the trail surface

Trailhead Signage

1. For each trailhead along recreational trails, provide signage with the following information:
 - the length of the trail
 - the type of surface of which the trail is constructed
 - average and minimum trail width
 - average and maximum running and cross-slopes
 - the location of features and amenities, where provided
 - extreme or unique conditions (e.g., steep slopes, obstacles or narrow widths)
2. Ensure signage adheres to established corporate branding and signage standards and text has high tonal contrast with its background to assist with visual recognition.

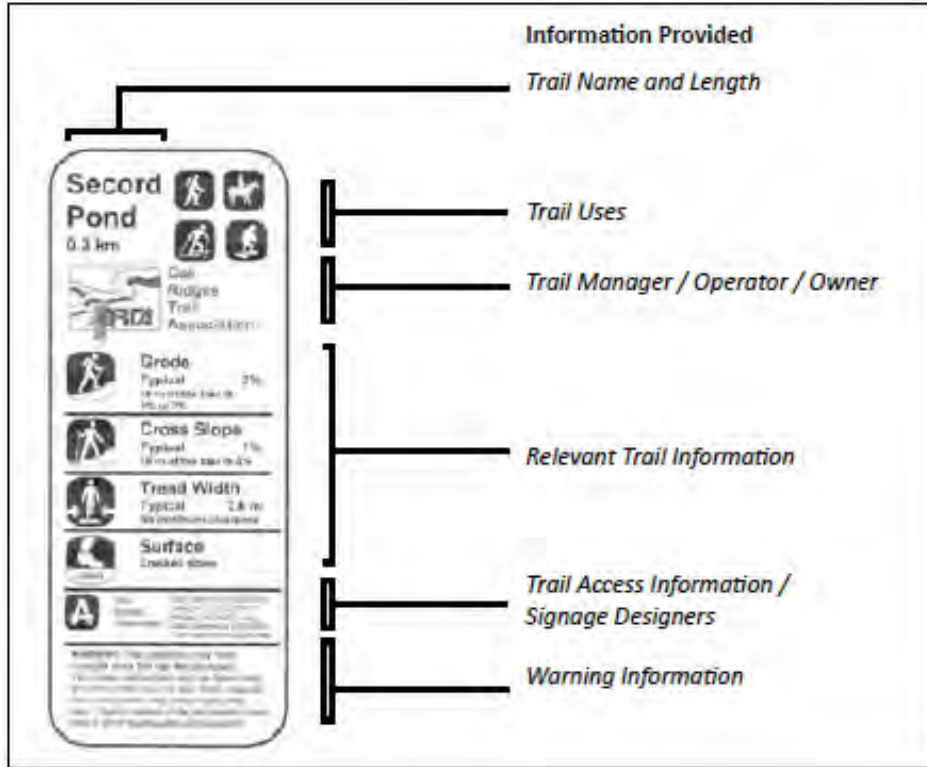

Figure 53: Example of a universal trail assessment

Beach Access Routes

Entrances

1. Provide 1.5 m clear opening whether entrance includes a gate, bollard or other entrance design

Clear Width

1. Provide clear width of 1.5 m (minimum)
2. Provide headroom clearance of 2.1 m (minimum) above beach access route

Surfaces

1. Ensure surface is firm and stable
2. ensure that openings must not allow passage of an object that has a diameter greater than 13 mm and that any elongated openings are oriented approximately perpendicular to the direction of travel
3. Where the surface of the route is constructed (e.g., not natural):
 - o ensure surface has 1:2 bevel at changes in level between 6 mm and 13 mm

- provide a maximum running slope of 1:10 (10%) at changes in level between 14 mm and 200 mm
- provide a ramp where changes in level are greater than 200 mm

Inclusive Play Spaces

How the standard applies

This section applies to play spaces designed for children. Play spaces can be located in a variety of public settings (e.g., parks, schools, childcare facilities or community/recreation centres). Play spaces typically require consideration for accessibility features related to:

- the number and types of play structures, equipment, elements and features provided
- play areas surrounding the play structures
- site amenities and features surrounding the play space

Criteria provided in this section is intended to summarize key features for inclusive play spaces and reference to applicable standards. Detailed planning and design are required for provision of inclusive play spaces.

STANDARDS

Consultation Requirements

When constructing new or redeveloping existing outdoor play spaces, consultation on the needs of children and caregivers with various disabilities must occur with:

1. The public and persons with disabilities
2. Haldimand County Accessibility Advisory Committee

Design Requirements

When constructing new or redeveloping existing play spaces:

1. Incorporate accessibility features, such as sensory and active play components, for children and caregivers with various disabilities into the design of outdoor play spaces
2. Ensure that outdoor play spaces have ground surface that is firm, stable and has impact attenuating properties for injury prevention and sufficient clearance to provide children and caregivers with various disabilities the ability to move through, in and around the outdoor play space

3. Ensure the design of inclusive play spaces and features meet the requirements of *CAN/CSA Z614-14, Annex H*, including:
 - H.1 Scope
 - H.2 Reference Publications
 - H.3 Reference Definitions
 - H.4 Play spaces (e.g., ground-level and elevated play components, accessible routes, transfer systems, play components and ground surfaces)
 - other applicable sections of these Standards, as required

Summary of Key Design Considerations

The information in the following sub-sections is intended to highlight key considerations only, not detailed specifications. Refer to requirements of the Canadian Standards Association (*CAN/CSA Z614-14, Annex H*). This information is not intended to duplicate existing standards, but is focused on presenting best practices for accessibility.

Entry and Exit Points

Provide a minimum of two accessible ingress/egress points:

1. Located as part of an adjacent accessible route
2. Ensure accessible connections provided to play space surfaces are firm, stable and slip-resistant, as well as providing direct connections to individual play components
3. Provide clear width of 1,525 mm (minimum)

Accessible Routes

1. Provide at least one accessible route within the boundary of the play space, connecting ground-level play components and elevated play components, including entry and exit points of the play components
2. Ensure clear width of accessible route is 1,525 mm (minimum)
3. Ensure the maximum slope for an accessible route connecting ground-level play components within the boundary of a play space is 1:16 (6.25%)

Play space Ground Surface

1. Provide accessible surface materials for play spaces such as poured-in-place rubber, accessible turf, rubber mats and tiles, bonded and engineered wood fibers or shredded rubber

Transfer Systems

1. Provide transfer systems to connect elevated or ground-level play components (e.g., transfer steps or platforms)
2. Ensure transfer steps are used where movement is intended from a transfer platform to a level that provides elevated play components on an accessible route
3. Provide a minimum clear floor space of 915 mm wide by 1,370 mm long adjacent to all transfer locations onto play components

Turning Space

1. Provide clear turning space for mobility aids of 1,675 mm (preferred) or 1,500 mm (minimum) diameter on the same level as play components



Figure 54: Turning radius on playset

Ground-Level Play Components

A ground-level play component is a play component that is approached and exited at the ground level.

1. Provide the ratio of ground-level play component alternatives, compared to elevated play components as identified in the table below.

Table 8: Ground-level component requirements

Number of Elevated Play Components provided	Minimum number of ground-level play components required to be on an accessible route	Minimum number of different types of ground-level play components
---	--	---

		required to be on accessible route
1	n/a	n/a
2-4	1	1
5-7	2	2
8-10	3	3
11-13	4	3
14-16	5	3
17-19	6	3
20-22	7	4
23-25	8	4
More than 25	8, plus 1 for each additional 3 over 25, or fraction thereof	5

Designing an Inclusive Play Space

Key Features of an Inclusive Play Space

Play spaces that offer children of all abilities the opportunity to interact and play with each other are essential to promoting diversity and inclusion.

The following diagram identifies important best practices when designing an inclusive play space.

Key features are numbered on the diagram below and described in this guide.

- 1 – Accessible Route
- 2 – Entry/Exit Point
- 3 – Ground Surfaces
- 4 – Elevated Surfaces
- 5 – Ground-Level Playing Components

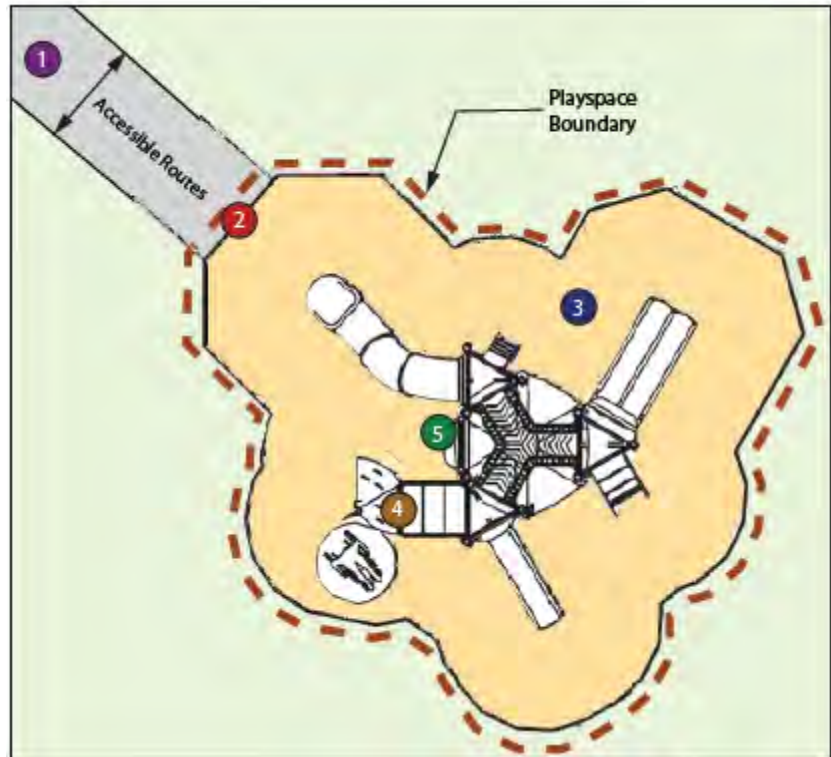

Figure 55: Example of typical play space features

Summary of 5 Key Features

Accessible Route

Accessible route(s) to the play space boundary from the parking lot, sidewalk and other adjacent routes and buildings are essential for easy access to the play space.

Key Consideration:

Is there at least one accessible route leading to the play space?



Accessible route connecting to play space.



Accessible route connecting to play space.

Entry/Exit Point

Entry/exit points to and from an accessible route along the boundary of the play space for users of mobility aids to access play components, where there is a change in level.

Key Consideration

Is there at least one entry/exit point (2 or more preferred) into the play space?



Play space is at-grade with accessible route.



Curb ramp into play space where there is a level change between accessible route and play space.

Ground Surfaces

Surfacing is a key component in designing safe and accessible play spaces. **Accessible surfaces** include poured-in place rubber, shredded rubber and engineered wood fiber.

Key Consideration

Is the play space ground surface accessible?



Shredded Rubber.



Engineered Wood Fiber.

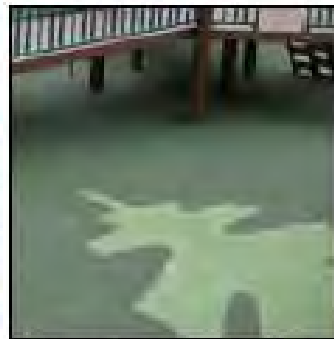

Poured-in-Place Rubber.

Elevated Surfaces

An elevated play component is a play component reached from above or below grade, and is part of a composite play structure.

Two common methods for providing access to elevated play components are **ramps** and **transfer systems**.

Ramps, transfer systems, steps, standalone slides, decks and roofs are not considered elevated play components.

Key Consideration

Are at least 50% of elevated play components located on an accessible route and connected by a ramp or transfer system?



Example of play structure with elevated play components.



Example of play structure with elevated play components.



Ramp connected to elevated play components.



Transfer system to connect elevated play components.

Ground-Level Playing Components

A ground-level play component is a play component that is approached and exited at ground level.

When designing an inclusive play space, one of the design features is the provision of play components along the accessible routes for users who may not be able to access components located on elevated platforms.

The number and variety of ground-level play components required to be on an accessible route is determined by the number of elevated play components provided in the play space.

Key Consideration

Are the minimum number and variety of ground-level play components along an accessible route provided?

A calculator to determine the required number and variety of ground-level and elevated play components required in an inclusive play space is provided in *CAN/CSA Z614-14, (Annex H)*.



Example of a ground-level play component.



Example of an accessible swing.

Appendices

Definitions

Access Aisle: Refers to an accessible and safe pedestrian space or route used for loading and unloading from vehicle, as well as safe travel to and from designated accessible parking spaces to nearest accessible route/entrance. Access aisles include pavement markings for easy identification and are often shared between accessible parking spaces.

Accessible: Refers to any space, feature, element, site, environment or facility that can be used (e.g., located, approached, entered, exited or operated) by people with varying disabilities, with or without the use of mobility aids or assistive devices. Can also refer to services, practices and programs.

Accessible Route: A continuous, unobstructed path (interior or exterior) connecting users to accessible elements, features, amenities and spaces. Typically, accessible routes include parking access aisles, pedestrian sidewalks and curb ramps and interior corridors, floors, elevators and ramps.

Accommodation: A term used to reflect how an individual's needs are met for unique circumstances where a solution may not be "technically" feasible or practical to implement. Where barriers continue to exist because it is impossible to remove those barriers at a given point in time, then accommodation should be provided to the extent possible, short of "undue hardship". There is no set formula for accommodating people with disabilities. Each person's needs are unique and must be considered afresh when an accommodation request is made. A solution may meet one person's requirements but not another's, although it is also the case that many accommodations will benefit large numbers of persons with disabilities. Accommodating an individual's needs through differential treatment must be achieved in a manner that maximizes integration and dignity.

Achievable: Possible to achieve or complete with the available resources and infrastructure without causing undue hardships.

Adaptable: The ability of a certain building space or element, such as kitchen counters, sinks, or grab bars, to be added or altered so as to accommodate the needs of individuals with or

without disabilities or to accommodate the needs of persons with different types or degrees of disabilities.

Ambient Light: The total amount of light in a space, including daylight or artificial light, whether from direct sources or reflected from surfaces in that space.

Amenities: Features or services that are usable by the public that typically increase physical comfort throughout the built environment (e.g., washrooms, resting areas, telephones, drinking fountains or food vending machines).

Amenity Strip: A section of a path or sidewalk that is set aside for placement of street furniture (e.g., benches, hydro poles, vending machines and post boxes), to ensure it is located away from pedestrian path of travel.

Anthropometrics: Refers to the study of human physical measurement, movement and proportions of the human body, with respect to reach ranges, sight lines, etc.

Area of Refuge (or Rescue Assistance): A safe holding area which has been designated in a Fire Safety Plan, with direct access to an exit and is equipped with separate ventilation and communication equipment. It is a place where people can wait temporarily until they can exit safely or await further instructions or assistance during an emergency evacuation.

Arena: Refers to an enclosed, indoor venue, often circular or oval-shaped and designed to showcase a variety of performance or sporting events (e.g., hockey, basketball, football or soccer) in a large open space, typically surrounded on most or all sides by tiered seating for spectators. Often, the key feature of an arena is that the event space is the lowest point, allowing for maximum visibility.

Assembly Area: A room or space accommodating a group of individuals for educational, recreational, political, social, civic or amusement purposes, or for the consumption of food and drink.

Assistive Listening Systems (ALS): Assistive listening systems (ALS) augment standard public address and audio systems by providing signals which can be received directly by persons with special receivers or their own hearing aids and which eliminate or filter background noise. The type of assistive listening system appropriate for a particular application depends on the characteristics of the setting, the nature of the program, and the intended audience. Magnetic induction loops, infrared and radio frequency systems are types of listening systems which are

appropriate for various applications. Refer to Induction Loop or Infrared Assistive Listening Systems.

Audible Signals: Signals which emit a distinctive sound, communication or alert to provide a warning or indicate a readiness to respond (e.g., alarm bell or signal).

Automatic Door: A door equipped with electronic sensors allowing it to be opened and triggered when pedestrians approach (e.g., typically sliding doors or swing doors equipped with guardrails for safety). See Power-Assisted Door.

Barrier: Refers to anything that prevents a person with a disability from fully participating in any aspect of society because of their disability. This can include a physical barrier, an architectural barrier, an information or communication barrier, an attitudinal barrier, or a technological barrier for example. It can also include policies and practices that result in an obstacle or hardship (e.g., systemic barrier).

Blended Curb: A connection with a slope of 1:20 (5%) or less between the level of a pedestrian walkway and the level of a crosswalk.

Bollard: Typically a 900 mm high (minimum) post to mark a pedestrian path from vehicular traffic.

Braille: Braille is a system of touch reading for the blind which employs embossed dots evenly arranged to represent numbers and letters. Literary Braille, as officially approved, comprises of two grades. Grade 1 Braille is in full spelling and consists of the letters of the alphabet, punctuation, numbers, and a number of composition signs which are special to Braille. Grade 2 Braille consists of Grade 1 and 189 contractions and short-form words, typically used for signage where space is limited.

Change Room: See Dressing Room.

Circulation Route or Path: An exterior or interior pedestrian way used for traveling from one place to another.

Clear Floor Space: The amount of unobstructed floor or ground space required to accommodate a single stationary user, or a mobility device/aid, such as wheelchairs, scooters, canes and crutches.

Closed Circuit: A telephone with dedicated line(s), such as a house phone, courtesy phone or phone that must be used to gain entrance to a building or part thereof.

Closer: See Door Closer

Common Use: Refers to those interior and exterior rooms, spaces or elements that are made available for regular and daily for use by the occupants or visitors of a facility. (e.g., common use areas of an office may include kitchens, reception areas, washrooms, etc.).

Communication Devices and Systems: Devices that enable or enhance the ability of people to receive or transmit information, usually electronically, for communication.

Cross-Slope: The slope that is perpendicular to the direction of travel. Opposite of running slope.

Crosswalk: That part of a roadway at an intersection that is marked for safe pedestrian crossing (e.g., by lines or other markings on the surface).

Curb Ramp: A ramp that is cut through a curb at a roadway and slopes up to a sidewalk. Types are usually categorized by their structural design and how they are positioned relative to the sidewalk and roadway. Permitted curb ramp types include:

- perpendicular - one that is aligned so that the ramp is generally perpendicular to the centreline of the roadway, and users will generally be travelling perpendicular to traffic when they enter the street at the bottom;
- parallel - one that has two ramps leading towards a centre level landing at the bottom; and
- combination of perpendicular and parallel.

Dais: Refer to Stage.

Deaf: A term to describe people with a severe to profound hearing loss (90 decibels or greater), with little or no residual hearing. Lowercase deaf is used when referring to the medical/audio logical condition of having little or no hearing, while uppercase Deaf refers to individuals who identify themselves as deaf and share a culture and community, not just a medical condition.

Deafened: A term used to describe individuals who grow up hearing or hard of hearing and suddenly, or gradually, experience a profound loss of hearing. Late-deafened adults usually

cannot understand speech without visual clues such as print interpretation (e.g., computerized note taking), speech reading or Sign Language.

Depressed Curb: a seamless gradual slope at transitions between sidewalks and walkways and highways, and is usually found at intersections.

Disability: Describes a functional limitation or activity restriction caused by an impairment. Common types include: sensory (e.g., vision or hearing), mobility, physical, cognitive, learning or mental health disabilities. Refer to the Ontario Human Rights Code for a detailed definition of disabilities.

Door Closer: A device or assembly used to open or close a door automatically.

Door Jamb: The vertical component of a door frame.

Dressing Room: Home or visiting team locker rooms that are not for the general public, but dedicated to the group using the playing areas (e.g., hockey arena, soccer field or basketball court). Generally, contains showers, benches and washroom amenities.

Egress (Means of): Means of egress refers to a continuous path of travel provided for the escape of persons from any point in a building leading to a point of safety (e.g., a separate building or an exterior open space protected from fire exposure), including exits and exit routes.

Elevator Lobby: The waiting area in front of an elevator.

Entrance: An access point into a building or portion of a building or facility used for the purpose of entering. An entrance includes the approach, the vertical access leading to the entrance platform, the entrance door, landing area, vestibules (if provided), the entry door or gate, and the hardware of the entry door or gate. The principal or main entrance of a building or facility is the door through which most people typically enter (e.g., highest level of use).

Exit: The part of a means of egress, including doorways, that leads from the floor area it serves to a separate building, an open public thoroughfare, or an exterior open space protected from fire exposure from the building and having access to an open public thoroughfare.

Facility: All or any portion of buildings, structures, elements, improvements, equipment and pedestrian or vehicular routes located on a site or in a public right-of-way, where specific programs or services are provided or activities performed.

Feasible: The capability of being done without causing undue adversity to build something above the minimum standard.

Fire Safety: A general term typically relating to the ability of a building or site to resist, suppress or control the onset and spread of fire and the protection of building occupants.

Fire Safety Plan: An operational plan that provides information, directions, strategies and recommendations for the safe evacuation of users during fire emergencies.

Firm Surface: Refers to a surface that does not deform under the vertical forces exerted by permitted users. Reference ASTM F 1951 Standard.

Flare Sides: A sloped surface that flanks a curb ramp and provides a graded transition between the ramp and the sidewalk. Flares bridge differences in elevation and are intended to prevent ambulatory pedestrians from tripping. Flares are not considered part of the accessible route.

FM Assistive Listening System: FM assistive listening systems are variations on the commercial FM radio. Radio signals are broadcast by an FM transmitter that is piggybacked on the sound system used in the facility. These signals are received by individual "radios", which are small pocket-size receivers tuned to the specific frequency used in the transmission.

Foot-Candle (FC): Refer to measurements of the visible light intensity on a surface, a distance from the light source. One foot-candle is equivalent to the illumination produced by one candle (an optical standard reference) at a distance of 305 mm (one foot). One foot-candle equals approximately ten lux. Foot-candle is the imperial measure. Refer to Lux.

Forward Approach: Where a person will make use of a service counter, drinking fountain, or any other usable element of the built environment, by positioning their body or mobility aid directly in front of and facing the element.

Glare: Often refers to uncomfortably bright light reflected from a surface, floor, window or screen. Glare occurs when one part of the environment is much brighter than the general surrounding area, causing annoyance, discomfort or loss in visual performance.

Grade: The slope parallel to the direction of travel that is calculated by dividing the vertical change in elevation by the horizontal distance covered.

Guard: Protective barrier to prevent accidental falls at openings in floors and at the open sides of stairs, landings, balconies, mezzanines and ramps. Handrail supports often act as guards.

Hard of Hearing: A term used to describe people with a hearing loss who rely on residual hearing to communicate through speaking and speech-reading, as well as to hold conversations on the telephone. The degree of hearing loss can range from mild to profound. People who are hard of hearing can understand some speech sounds, with or without a hearing aid, and communicate primarily by speech. Persons who are hard of hearing often use hearing aids, lip reading and other assistive technologies.

Illumination: The combined amount and intensity of lighting provided, measured in foot-candles or lux.

Kilonewton (kN): Equals 1000 Newtons.

Induction Loop Assistive Listening System: Induction loop assistive listening systems use a wire around the room to transmit an electromagnetic signal that is picked up by a small telecoil in the hearing aid. Users simply switch on this telecoil (the "T" setting) and adjust the volume of the hearing aid, if necessary. Loop systems are generally used by fewer people with hearing loss due to advances in hearing aid technology.

Infrared Assistive Listening System: Infrared assistive listening systems operate on infrared light that is beamed from one or several infrared transmitters to small, specialized receivers. There are several types of infrared receivers: stethoscope-style that dangle from the ears, a headset type that fits over the ears, and a small pocket-size type similar to the FM receiver. Where confidential transmission is essential (e.g., a court room setting), an infrared system generally is more effective recognizing transmission will be restricted within a given space.

Lavatory: A washbasin or sink used for personal hygiene.

Lux: The metric measurement for light intensity or illumination. See Foot-Candle.

Maneuvering Space: The minimum floor or ground area needed for users of mobility aids to move into or out of a place, space or along an accessible pathway or route.

Mixed-use: When referring to a path of travel, mixed-use is to be understood as a path that is used for walking, running, strollers, mobility aides, bicycles, scooters, etc.

Mobility Aids (or Devices): A term used to encompass the variety of assistive devices used by people with mobility/physical types of disabilities, including manual and power wheelchairs, scooters, canes and crutches.

Newtons (N): The amount of force needed to move 1 kilogram of an object 1 meter per second squared.

Operable Control: The part of equipment or appliances that is used to insert or withdraw objects, to activate or deactivate, or to adjust the equipment or appliance (e.g., a coin slot, pushbutton or handle).

Operable Portion: A part of a piece of equipment or appliance, used to insert or withdraw objects or to activate, deactivate or adjust the equipment or appliance, such as a coin slot, push button or handle.

Passenger Loading Zone: Designated and signed area used for loading and unloading of passengers into or out of a waiting vehicle.

Pedestrian Access Route: An accessible route or corridor for pedestrian use within the public right-of-way.

Pictogram: A pictorial symbol or image that represents activities, facilities, spaces or concepts.

Platform Lift: An elevating device which is used to transport a person (with or without assistive equipment) between levels on a platform. A vertical platform lift is a self-contained unit, with or without an enclosure. An inclined platform lift is used for staircases.

Power-Assisted Door: A door with a mechanism that opens the door automatically, upon the activation of a switch, button or a control. The door also remains in the "open" position for a set period of time to allow safe passage. See Automatic Door.

Public Entrance: An entrance that is not a service entrance or a restricted entrance.

Public Use: Buildings, facilities and interior or exterior rooms, spaces, sites or elements that are made available to the public and that are typically owned, operated or leased by the Haldimand County.

Ramp: A walking surface with a running slope steeper than 1:20.

Rest Areas: A rest area is a dedicated level area that is intended for public use to allow persons to stop or sit. A typical rest area consists of a bench with armrests and backrests; a clear space to accommodate mobility aids; and a ground surface that contrasts the sidewalk or multi-use path.

Running Slope: The slope that is parallel to the direction of travel expressed as a ratio of rise to run. Opposite of cross-slope.

Service Counter: A raised surface on which business is transacted. Service counters can be comprised of either built-in (e.g., kiosks) or loose furniture (e.g., podiums). Other examples of service counters include: ATMs, checkout counters, self-service kiosks, food vendor, and information counters.

Naturalized Trail: Typically, these trails are located in naturalized areas and feature more naturalized paths of travel that conform to the landscape.

Service Entrance: An entrance not intended for use by the public and used primarily for delivery of goods and services.

Side Approach: Where a person will make use of a service counter, drinking fountain, or any other usable element of the built environment, by positioning their body or mobility aid perpendicular to the element.

Sidewalk: A public right-of-way designated for pedestrian use and typically located between the curb or roadway and the adjacent property line.

Sightline: The line of view between a person in an audience and a performance, speaker or displayed item.

Sign or Signage: A sign is a means of conveying information about direction, location, safety or form of action and in general should be designed to be clear, concise and consistent. Signage displays text, symbols, tactile or pictorial information.

Site: A parcel of land bounded by a property line or a designated portion of a public right-of-way.

Slip-Resistant: A surface that provides sufficient frictional counterforce to the forces exerted in walking to permit safe ambulation.

Sprinklered: Refers to a building or any part of a building equipped with an automatic sprinkler system.

Stable Surface: Refers to a surface that does not deform or erode under the angular forces of permitted users travelling in a straight line or turning.

Stage: Refers to a space designed primarily for performances and is typically elevated from the audience seating area.

Stair System: Refers to combined elements that make up a typical stair, including steps, landings, and handrails, for example.

Street Furniture: Elements in the public right-of-way that are intended for use by pedestrians, including benches, lighting fixtures, waste dispensers and paper vending machines, for example.

Tactile: Describes an object that can be perceived using the sense of touch, and typically provided for users with vision loss.

Tactile Walking Surface Indicator (TWSI): A surface detectable underfoot or by a long white cane, to assist persons with low vision or blindness by alerting or guiding them.

Touch Tour: Typically refers to tours provided by museums or other cultural/arts facilities that allow users with vision loss to touch and feel objects, displays and features, for example to gain a sensory understanding of objects and allow individual exploration. Tactile experiences may include: replicas, models, props, and handling objects which convey one aspect of the work.

Transfer Space: An unobstructed area adjacent to a fixture or furniture, allowing the positioning of a mobility aid to assist users with transferring to the fixture or furniture.

TTY, Teletypewriter or Text Telephone: TTY is the abbreviation for "teletypewriter" and refers to a means of electronic communication between deaf people or deaf and hearing people using interactive, text-based communication. Used in conjunction with a telephone, this device transmits and received typewritten messages using coded signals across the standard telephone network. The term TTY also refers to devices known as "text telephones" and TDD's.

Universal Access: A broad term to reflect the intended goal of inclusion for all, based on the principles of universal design or the "design of products and environments to be usable by all

people, to the greatest extent possible, without the need for adaptation or specialized design” (Ron Mace).

Urban Centric Trail: A trail that is located, typically, within a community surround by housing and businesses.

Video Signage: Video signage refers to video devices such as televisions, computer monitors/screens, and flat panel displays that may be used to provide information (e.g., directories). Advantages of video signs include the use of motion to attract attention, and the ability to rapidly update the content of the signs.

Vision Loss: This term usually refers to a progressive decrease in visual acuity. However, it can refer to the sudden onset of substantial acuity decrease or total blindness.

Vision Panel: A glazed opening in a door leaf which allows people to see through to the other side without opening the door.

Wayfinding: A term used to describe a variety of means for spatial orientation and finding your way to a destination. Wayfinding design describes a variety of means for helping people find their way, through touch, print, signage, architecture and landscaping, for example.

Regulatory Framework

The development of these Standards is driven by the regulatory environment and important Provincial accessibility legislation and related requirements, which also supports the County's position and initiative to be proactive and a leader in developing inclusive communities.

While Haldimand County's Accessibility Design Standards (ADS) have been developed to assist with compliance with relevant legislation and related requirements, users are cautioned that the ADS by no means attempts to duplicate all the details of those references. Users must be familiar with the relevant legislation that affects a particular project or situation to ensure compliance.

The regulatory framework from which the ADS draws is summarized as follows:

The Ontarians with Disabilities Act, 2001

In December 2001, the Government of Ontario passed the *Ontarians with Disabilities Act, 2001* (ODA) to improve opportunities for people with disabilities. Under the ODA, municipalities, regardless of size, must prepare annual accessibility plans and make them available to the public. Municipalities must also include people with disabilities in the planning process, either as members of formal accessibility committees that are required to be established under the Act, or as participants in the consulting process.

Municipal Accessible Advisory Committees (AAC's) must be established by municipalities with populations over 10,000. Under the ODA, accessibility plans are required to review and report on barriers that are identified within a municipality's buildings, facilities, programs, practices, services, by-laws and policies. Accessibility plans must also report on the steps that the municipality has taken to identify, remove and prevent barriers for people with disabilities.

In summary, municipal accessibility plans are required to include the following:

- Measures taken to identify, remove and prevent barriers to persons with disabilities;
- Measures in place to ensure that proposals for by-laws, policies, programs, practices and services are formally evaluated to determine their effect on accessibility for persons with disabilities;
- A list of the by-laws, policies, programs, practices and services that will be reviewed in the year the plan is implemented in order to identify barriers to persons with disabilities;
- The steps and initiatives to take place annually that will identify, remove and prevent barriers to persons with disabilities;
- How the accessibility plan and related information is made available to the public; and

- The steps to consider accessibility in planning processes as well as when procuring goods and services from companies, granting business licenses and approving plans for subdivisions.

Overall, the ODA does not expect municipalities to remove every existing barrier immediately, allowing for the removal of barriers to accessibility over time. The ODA provides municipalities with flexibility to identify their own priorities and to decide on what level of detail they will include in their annual accessibility plans. This is based on the recognition and assumption that accessibility plans must be developed on sound planning principles, with issues addressed according to priorities and needs identified during the public consultation process.

The Accessibility for Ontarians with Disabilities Act (AODA, 2005)

The Accessibility for Ontarians with Disabilities Act, 2005 (AODA) came into effect on June 13, 2005. Although the AODA is now law, the planning requirements of the ODA still remain in force. Section 29 of the AODA continues the AAC's role to review site plans under the *Planning Act*, and to advise municipal council on issues related to the accessibility of the built environment, including municipal sites and facilities.

Additionally, the AODA requires accessibility standards to be established by the Province. In summary, the purpose of the AODA is to:

- Develop, implement and enforce accessibility standards in order to achieve accessibility for Ontarians with disabilities with respect to goods, services, kiosks, facilities, accommodation, employment, buildings, structures and premises by January 1, 2025.
- Provide for the involvement of persons with disabilities, the Government of Ontario and representatives of industries and of various sectors of the economy in the development of accessibility standards.

The Province of Ontario established "Standards Development Committees" (SDC's) in the areas of customer service, transportation, information and communications, the built environment and employment.

These provincial accessibility standards set out the measures, policies, practices and other steps needed to improve and prevent barriers for people with disabilities. The standards apply to both the public and private sector. Currently there are two regulations in place in Ontario: The Accessibility Standards for Customer Service Regulation and the Integrated Accessibility Standards Regulation.

AODA Accessibility Standards

Accessibility standards have been developed as part of the AODA standards development process, including:

The **Integrated Accessibility Standards Regulation (IASR)**, Ontario Regulation 191/11, includes general requirements as well as sections on Customer Service, Information and Communication, Employment, Transportation and the Design of Public Spaces. The Haldimand County Accessibility Design Standards have been prepared in response to the IASR general requirement on procurement which states that designated public sector organizations shall incorporate accessibility design criteria and features when procuring or acquiring goods, services, or facilities, except where it is not practicable to do so.

- **Customer Service:** States what businesses and other organizations in Ontario must do to make the provision of their goods and services more accessible to people with disabilities. For municipalities, it requires an accessible customer service policy, practices and procedures, along with employee training.
- **General Requirements:** Regulatory requirements that apply across all standards of the IASR.
- **Information and Communications:** Identifies how organizations are required to create, provide and receive accessible public information and communications in various formats such as online, print, verbal and digital.
- **Employment:** Requires employers to provide for accessibility across all stages of the employment life cycle.
- **Transportation:** Requirements to make services and vehicles accessible to people with disabilities.
- **Design of Public Spaces:** Addresses exterior areas of the built environment, such as outdoor paths of travel, recreational trails, playgrounds, accessible on and off-street parking and service-related elements.

The Ontario Human Rights Code (OHRC)

The Ontario Human Rights Code ('the Code') protects all Ontario residents from discrimination and harassment in specific areas including services, housing, contracts and employment. Under the Code, every person has a right to equal treatment with respect to services, goods and facilities, without discrimination because of disability, race, ancestry, place of origin, colour, ethnic origin, citizenship, creed, sex, sexual orientation, age, marital status, same-sex partnership status, and family status. Further, the Code recognizes that people with disabilities have the right

to be able to access services, jobs and housing, with the right to assume the same responsibilities and duties as everyone else.

Employers, landlords, service providers and others have a duty to consider the needs of people with disabilities. This can include ways to apply the principles of inclusive or universal design for the construction or renovation of buildings and facilities, as well as their application to related processes, programs and services. If systems, facilities or other elements of the built environment or people's attitudes create discriminatory barriers, then they must be removed or changed. Where it is impossible to remove these barriers without undue hardship, then accommodations must be made so that people with disabilities can participate fully.

In summary, there are two important concepts related to the Ontario Human Rights Code that are critical to recognize as the County's Accessibility Design Standards are implemented: The Ontario Human Rights Code has primacy over all other provincial legislation including the Ontario Building Code, the *Ontarians with Disabilities Act, 2001* and the *Accessibility for Ontarians with Disabilities Act, 2005*; and Its intent is to remedy the situation for the person and to prevent further barriers.

The Ontario Building Code (OBC, 2012)

Accessibility amendments to Ontario's Building Code came into force on January 1, 2015. The accessibility requirements, or "barrier-free design" requirements as they are referred to in the OBC (Section 3.8), are generally recognized as representing a minimum standard for accessibility.

The requirements of the OBC specifically related to accessibility can be summarized as follows:

- Applies to most new construction and extensive renovation; and
- Amended requirements cover a range of areas, such as parking, entrances, elevators, washrooms, barrier-free access, ramps, stairs, signs and exits.

Most importantly, compliance with the OBC does not constitute compliance with the Ontario Human Rights Code. This is a key reason why additional accessibility design standards for the built environment are required to address the needs of users with varying disabilities.

Canadian Standards Association "Accessible Design for the Built Environment" (CSA B651-12)

Currently the Canadian Standards Association's "Accessible Design for the Built Environment" (CSA B651-12) is recognized as a voluntary national built environment standard for Canada. The CSA requirements were updated in 2012 and it is considered more comprehensive than the

OBC. However, the CSA also has limitations; for example, the CSA contains very little with respect to signage and wayfinding accessibility requirements, or fire and life safety issues. Overall, Haldimand County's Accessibility Design Standards go above and beyond the minimum requirements of the OBC and the CSA B651-12, representing a "best practice" approach to providing accessible design.

The OBC will be followed as required by law, however, there is no reason that the County's enhanced design standards for accessibility cannot be implemented where the intent and formal requirements of the OBC is also achieved.

The Ontario Planning Act

Overall, the *Planning Act* provides the legislative framework for land use planning in Ontario. It is the basis for the provincial interests relative to municipal land use planning, local planning administration, the preparation of planning policies, development control, land division and the public's right to participate in the planning process. Following the passing of the ODA, the Province amended the *Planning Act* in several sections, summarized as follows:

Section 2: Provincial Interest

Section 2 of the *Planning Act* requires planning authorities, in carrying out their responsibilities under the Act, to have regard to accessibility for persons with disabilities for all facilities, services and matters to which the Act applies. Therefore, those who have the responsibility for making planning decisions in the municipality and the province shall consider the level of accessibility for people with disabilities to all facilities and services that are guided by the Act.

Section 41: Reviewing Site Plans

The *Planning Act* makes provisions for accessibility for persons with disabilities as part of the site plan process. Site plan control helps facilitate universal accessibility to buildings and the spaces surrounding the buildings on a development site. Through this process, municipalities can review a developer's plans and drawings, and require the provision of facilities for accessibility to a development proposal. Section 12(5) of the ODA also specifies that if a municipality has an AAC, it may request to review site plans and drawings described in Section 41 of the *Planning Act* (site plan control) that are submitted to support planning applications. Section 12(6) of the Act identifies that municipal councils must supply such drawings to an AAC in a timely manner.

Section 51: Reviewing Plans of Subdivision

Under the *Planning Act*, when considering a draft plan of subdivision, planning approval authorities are to have regard to accessibility for persons with disabilities. Further, section 51

now allows approval authorities to require land dedication for pedestrian and bicycle pathways, and public transit ways in new subdivision proposals.

Section 53: Reviewing Applications to Sever Land (Consents)

When reviewing consent applications, municipalities need to have regard to accessibility for persons with disabilities. This is similar to the provision regarding the review of plans of subdivision. [Source: Adapted From "The Planning Act and Accessibility". Ontario Ministry of Municipal Affairs and Housing]

Exceptions

When exceptions to the Accessibility Design Standards are approved by the appropriate Haldimand County authority, those exceptions must be thoroughly documented and provided in writing to both Haldimand County, which is overseeing the work as well as the Haldimand County Accessibility Coordinator (accessibility@haldimandcounty.on.ca).

Financial constraints are not typically regarded as an acceptable rationale for an exception to be approved.

There are some exceptions allowed by the IASR which are specifically related to heritage, historic, or environmental effects. The IASR also notes exceptions where it is not practicable to comply with those requirements because existing physical or site constraints prohibit modification or addition of elements, spaces or features - examples are noted with the individual subsections of the IASR.

Principles Of Universal Design

Equitable Use-The design is useful and marketable to people with diverse abilities.

Flexibility in Use -The design accommodates a wide range of individual preferences and abilities.

Simple and Intuitive -Use of the design is easy to understand, regardless of the user's experience, knowledge, language skills or current concentration level.

Perceptible Information -The design communicates necessary information effectively to the user, regardless of ambient conditions or the user's sensory ability.

Tolerance for Error -The design minimizes hazards and the adverse consequences of accidental or unintended actions.

Low Physical Effort -The design can be used efficiently and comfortably and with a minimum of fatigue.

Size and Space for Approach and Use -Appropriate size and space is provided for approach, reach, manipulation and use regardless of user's body size, posture or mobility.

Understanding Disability

Using a Cross-Disability Perspective

Knowledge of the basic characteristics of different disabilities and the resulting barriers is critical towards understanding individual needs and how to address them when designing the built environment. Common “types” of disabilities are identified within these Standards to assist with understanding how users with disabilities interact with elements of the built environment. A list of key “types” of disabilities includes but are not limited to:

- Auditory Disabilities
- Intellectual Disabilities
- Physical Disabilities
- Developmental Disabilities
- Visual Disabilities
- Learning Disabilities
- Mental Health Disabilities

Haldimand County will always strive to consider “Universal Abilities”. The intent is to recognize and understand that everyone will experience variations in abilities throughout their lifespan, or ‘universal’ abilities. This approach considers no distinction between people with or without disabilities, focusing on identifying what is usable and safe for everyone in the community. The focus is also on extending the ideals of accessible design to routinely under-served populations, like people of short stature, seniors, pregnant individuals, parents with children in strollers, people who speak different languages and others.

Implementation Alternatives

Consistent with the policies of national and international accessibility standards, the information within these Standards is not intended to prevent the use of other designs, products or technologies as alternatives to those identified. This assumes that the implementation of these alternatives will result in an equivalent or an increased level of accessibility, meeting the principles of universal accessibility.

Implementation alternatives will be evaluated on a project-by-project basis by County staff, in collaboration and consultation with all relevant stakeholders, including the Haldimand County's Accessibility Advisory Committee, as required.

It is the intent of the County to review these Standards annually to ensure the highest level of accessibility is achieved and to ensure the Standards reflect any future changes to the legislation.

Feedback

Haldimand County recognizes that accessibility best practices continue to evolve and change over time, with the expectation that these Standards are recognized as a "living document" and will be updated on a regular basis. A feedback form is provided below, for any recommendations on how to improve this document or to provide new information.

